

# **Operator's manual** **DT22**



Please read these instructions carefully and make sure you understand them before using the machine.

**English**

---

# TABLE OF CONTENTS

---

## Operating Instructions for Lawn Dethatcher DT22 with supplement for accessories

<b>Introduction</b> .....	<b>2</b>	<b>Maintenance</b> .....	<b>24</b>
Congratulations .....	2	Maintenance schedule .....	24
Use .....	2	Replacing the air filter .....	25
Insure your machine .....	2	Cleaning the sludge reservoir .....	26
Good service .....	2	Idle adjustment .....	26
Serial number .....	2	Ignition system .....	27
<b>Symbols and decals</b> .....	<b>3</b>	Cutting unit .....	28
Decals and machine-bound instructions ...	3	Two minute rule .....	33
Location of decals .....	4	Cleaning and washing .....	32
Translation of instructions .....	5	<b>Lubrication</b> .....	<b>33</b>
<b>Safety instructions</b> .....	<b>6</b>	Lubrication schedule .....	33
General use .....	6	General .....	33
Preparations .....	8	Engine oil .....	34
Operating .....	9	Depth knob with depth lock .....	35
Movement/Transport .....	10	Blades .....	35
Storage .....	10	Depth lever .....	35
Children .....	10	Handle .....	35
Fuel system .....	11	<b>Troubleshooting</b> .....	<b>36</b>
Maintenance .....	12	<b>Storage</b> .....	<b>37</b>
<b>Presentation</b> .....	<b>13</b>	Winter storage .....	37
Presentation .....	13	Service .....	37
Main components and operating instruments .....	14	<b>Technical data</b> .....	<b>39</b>
Engine .....	15	<b>Assembly instructions</b> .....	<b>40</b>
Cutting unit .....	19	Assembly – delivery service .....	40
Blade versatility .....	20	Assembly directions, catcher bag .....	41
Setting blade height .....	20	Assembly directions, seed hopper .....	42
<b>Operation</b> .....	<b>21</b>	<b>Supplement</b> .....	<b>44</b>
Starting the engine .....	21	Instructions for the catcher bag .....	44
Cutting the engine .....	22	Instructions for the seeder .....	46
Before you start .....	23	<b>Service journal</b> .....	<b>50</b>
Starting .....	23	Delivery service .....	50
Finishing .....	23	After the first 20 hours .....	50

---

# INTRODUCTION

---

## Congratulations

Thank you for purchasing a Husqvarna lawn care product. Through your confidence in us, you have chosen an exceptionally high quality product.

This manual is a valuable document. It describes your new Husqvarna machine. Read the manual carefully before attempting to use the machine. Following the instructions (use, service, maintenance, etc.) can considerably increase the lifespan of your machine and even increase its resale value. Please contact your dealer for more information.

If you sell your Husqvarna machine, make sure to give the operator's manual to the new owner.

## Use

The dethatcher is used to remove the layer of thatch and surface-treat lawns, i.e. power-raking, de-mossing and collecting thatch in the form of old grass or moss. With an attachment, it can even be used for seeding, both in initial sowing or overseeding.

## Insure your machine

Contact your insurance company to check on insurance coverage for your new machine. You should have all-inclusive insurance for liability, fire, damage and theft.

## Good service

Husqvarna's products are sold all over the world and only in specialized retail trade with complete service. This ensures that you as a customer get only the best support and service. Before the machine was delivered it underwent inspection and was adjusted by your dealer. When you need spare parts or support in service questions, guarantee issues, etc., please consult the following professional:

This Operator's Manual belongs to machine with serial number:	Engine number:

## Serial number

The machine's serial number can be found on the printed plate attached to the rear side panel of the machine. The plate includes the following information:

- The machine's type designation (MODEL).
- The machine's serial number (S/N).

Please state the type designation and serial number when ordering spare parts.

The engine's serial number is punched in the crankcase above the oil drainage screw.

The engine type is specified on the crankcase under the air filter but also appears on the decal on the starter.

Please state engine serial number and type when ordering replacement engine parts.

# SYMBOLS AND DECALS



Used in this publication to notify the reader of a risk of **personal injury**, particularly if the reader should neglect to follow instructions given in the manual.



Used in this publication to notify the reader of a risk of **material damage**, particularly if the reader should neglect to follow instructions given in the manual.  
Used also when there is a potential for misuse or misassembly.

## Decals and machine-bound instructions

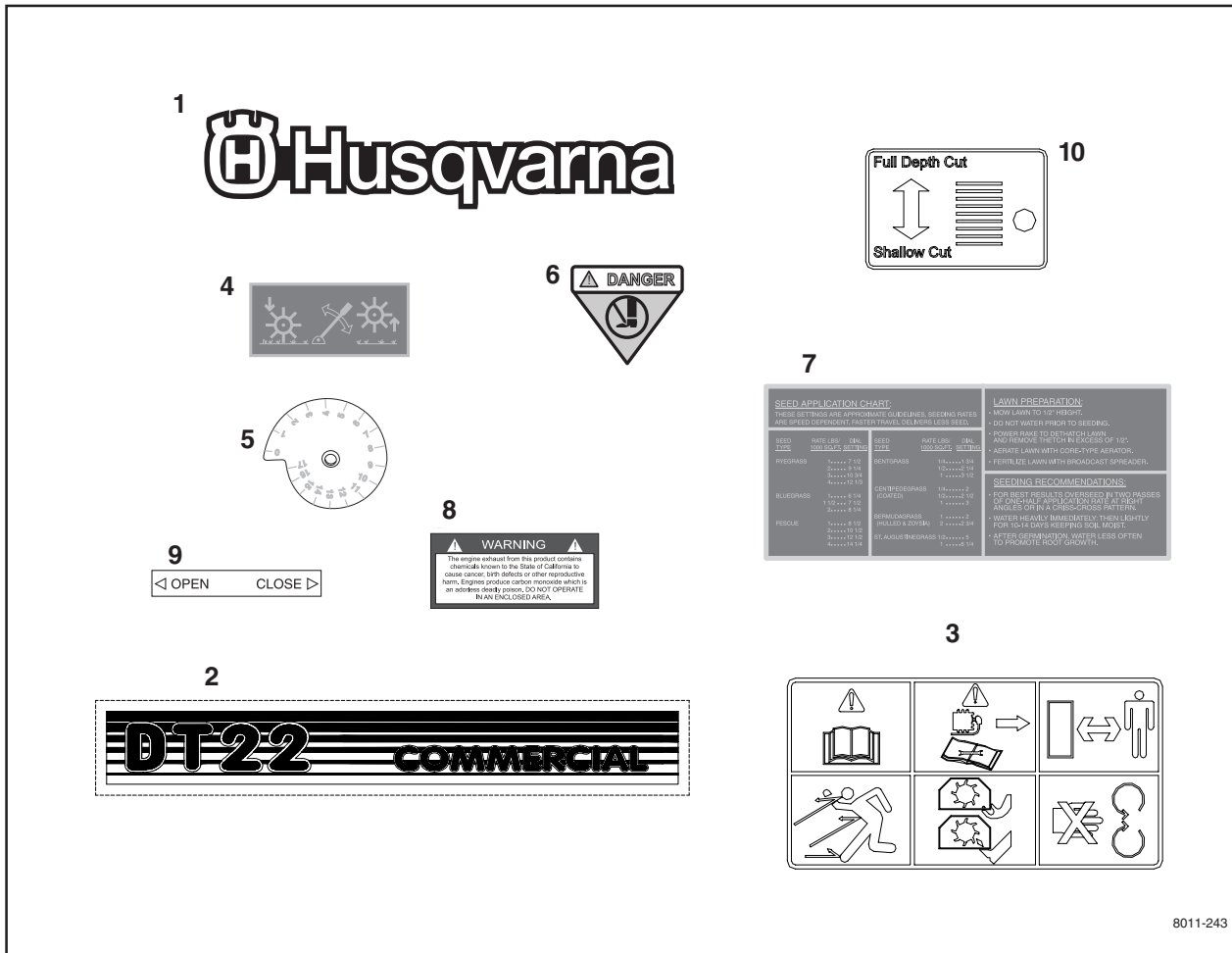

8011-243

- |                           |                                |
|---------------------------|--------------------------------|
| 1. Husqvarna logo         | 6. DANGER Watch your feet      |
| 2. Model designation DT22 | 7. Seed application chart      |
| 3. Caution list           | 8. Warning for carbon monoxide |
| 4. Height setting         | 9. Open/Close                  |
| 5. Dial                   | 10. Transport/Engaged          |

# SYMBOLS AND DECALS

## Location of decals

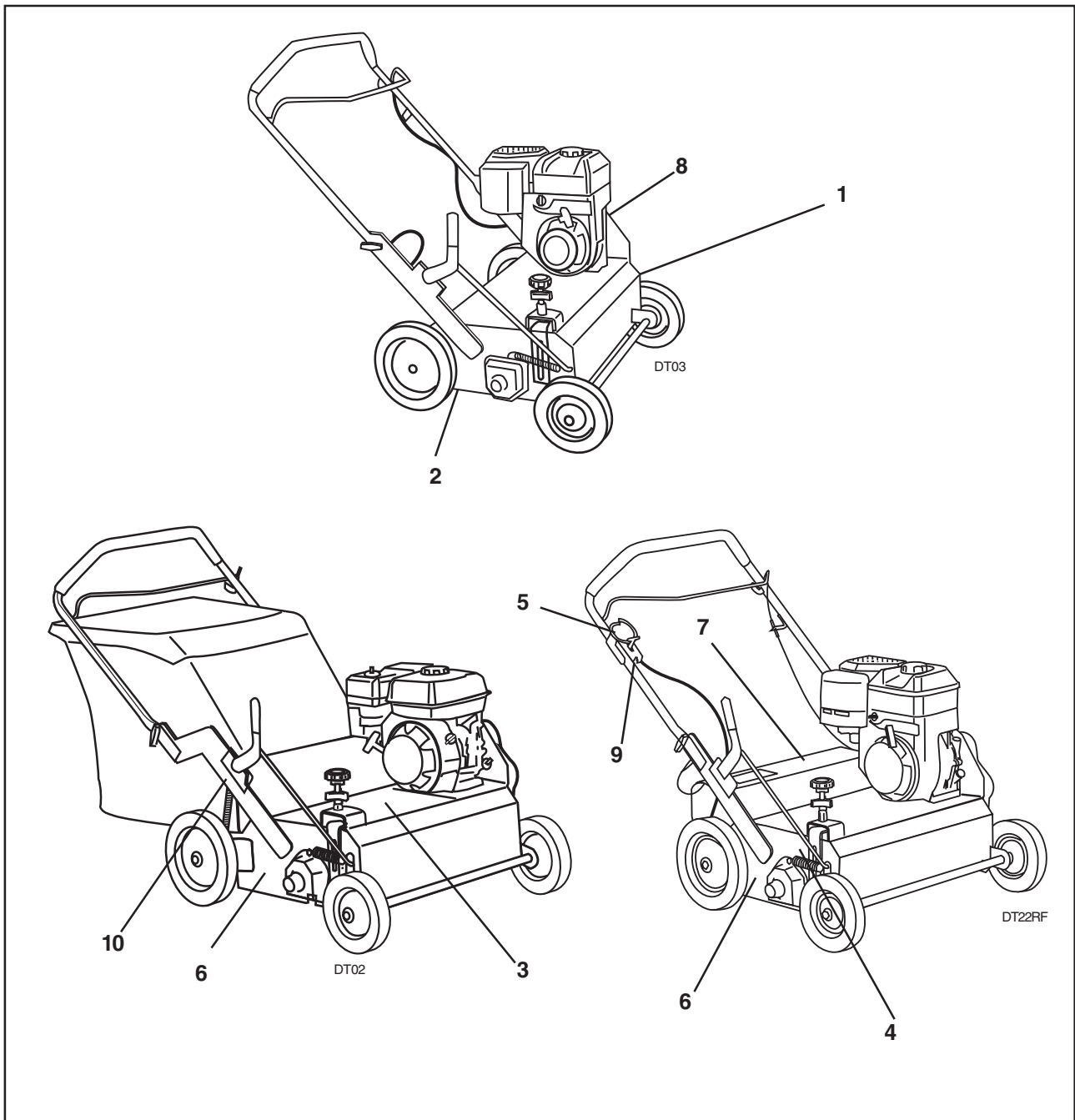

- |                           |                                |
|---------------------------|--------------------------------|
| 1. Husqvarna logo         | 6. DANGER Watch your feet      |
| 2. Model designation DT22 | 7. Seed application chart      |
| 3. Caution list           | 8. Warning for carbon monoxide |
| 4. Height adjust          | 9. Open/Close                  |
| 5. Seed Dial              | 10. Transport/Engaged          |

---

# SYMBOLS AND DECALS

---

## Translation of instructions

### Decal 7

#### Seed application chart

Values are approximate; quantities of seed depend on the speed at which the machine is run. Faster running speed results in sparser sowing.

#### Preparing the lawn

- Cut the grass to approximately 1-1.5 cm (1/2") shorter than normal.
- Do not water before sowing.
- Remove the layer of old grass cuttings (thatch).
- Aerate the lawn with a ground aerator of the coring type.
- Fertilize the lawn.

#### Seed application recommendations

- For best results, sow in two directions with a 45° angle between.
- Water generously immediately afterward and continue watering moderately for 10–14 days to keep the soil moist.
- After germination, water sporadically to encourage root growth.

### Decal 8

#### Warning

Engine exhaust, some of its constituents and certain vehicle components contain or emit chemicals considered by the State of California to cause cancer, birth defects or other reproductive harm. The engine emits carbon monoxide, which is a colorless, poisonous gas. Do not use the machine in enclosed spaces.

### Decal 3

#### Important information

Read and make sure you understand the Operator's Manual before use or maintenance.

To obtain a replacement manual, please contact your dealer.

Observe all safety instructions; otherwise you may injure yourself or others around you.

Make sure that the machine is in serviceable condition prior to use.

Make sure that all protective devices are in place when the machine is in use.

Stop the engine and wait until all machine movement comes to a standstill before service, adjustment or cleaning.

Do not run the engine in poorly ventilated spaces.

Make sure nobody is in the vicinity of the machine before starting and during use.

Avoid slopes that are too steep to use the machine safely.

Clear any debris from the lawn prior to use.

# SAFETY INSTRUCTIONS

## General use

The object of this manual is to help you use your Husqvarna machine more safely and to give you information about how to maintain your machine. Please read the manual carefully before attempting to use the machine.

If after reading the operator's manual you are still unsure about the safety risks associated with use of the machine, you should not use the machine. Please contact your dealer for more information.

These safety instructions only address the basics for safe use. It would be impossible in the safety instructions to describe all possible risk situations that could arise when using the machine. You can, however, prevent accidents by always using common sense.

To obtain extra copies of the operator's manual, please contact your dealer.

### IMPORTANT INFORMATION

**Do not use the machine until you have read the operator's manual carefully and understand the instructions given. All maintenance work or adjustments not described in this manual must be performed by an authorized Husqvarna service workshop.**

- Read this manual carefully and make sure you understand it before using the machine or performing any maintenance. If the user cannot read this manual, it is the responsibility of the machine owner to explain the contents to the user.
- Follow all safety instructions. Failure to do so may result in injury to yourself or others.
- Accident prevention regulations, other general safety regulations, occupational safety rules and traffic regulations must be followed without fail.
- All users shall be trained in use of the machine. The owner is responsible for training users.
- Engage an authorized Husqvarna workshop for all service and repairs not described in this manual.



### WARNING!

**Under no circumstances may the original design of the machine be modified without written approval from the manufacturer. Such modifications not only affect the performance and durability of the machine but may even pose a safety risk for users and those in the vicinity. Unauthorized modifications to the design of the machine may absolve the manufacturer from liability for any resulting personal injury or property damage. Modifying the machine without written approval from the manufacturer may void the guarantee.**

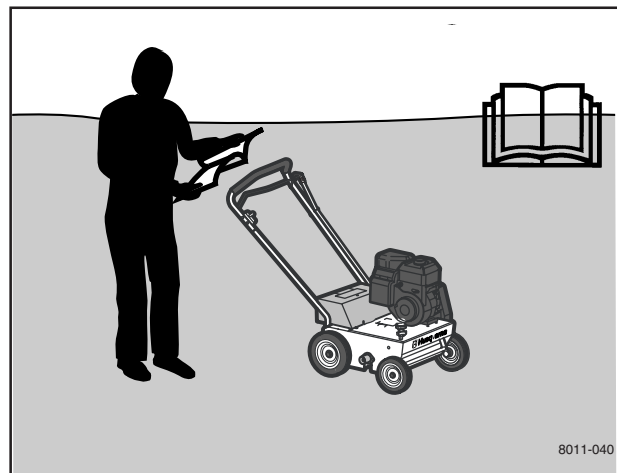

*Read this manual carefully before starting the machine.*

---

# SAFETY INSTRUCTIONS

---

- Husqvarna original spare parts are designed and specified to maintain high quality and correct fit for optimal durability and lifespan. From a safety point of view, you should only use Husqvarna original spare parts.
- Check that all safety decals are in place. See the chapter "Symbols and decals".
- Learn how to use the machine and its controls safely and learn to recognize the safety decals.
- Only use the machine for sowing and dethatching lawns. It is not intended for any other use.
- Check that the machine is in serviceable condition prior to use; see the chapter "Maintenance/Maintenance schedule".
- Only use the machine in daylight or in other well-lit conditions. Keep the machine a safe distance from holes or other irregularities in the ground. Pay attention to other possible risks.
- Only allow the machine to be used by adults who are familiar with its use.
- Never allow children or persons not trained in the use of the machine to use or service it. Local laws may regulate the age of the user.
- People and animals can distract you causing you to lose control of the machine. For this reason, you should always concentrate and focus on the task at hand.
- Never leave the machine unsupervised with the engine running.
- Make sure that other people are nearby when you are using the machine so that you can call for help should an emergency arise.
- The machine is tested and approved only with the equipment originally provided or recommended by the manufacturer.



## **WARNING!**

**The engine can become very hot. To avoid being burned, you must turn off the engine and wait until all parts have cooled before touching the engine.**



## **WARNING!**

**Overexposure to vibration may lead to circulatory or nerve damage, particularly in people who have impaired circulation. Contact your doctor if you experience symptoms that could have been caused by overexposure to vibration. Examples of common symptoms include numbness, pain, muscle weakness, change of skin color or an uncomfortable feeling of tingling. These symptoms appear most frequently in the fingers, hands or wrists.**

# SAFETY INSTRUCTIONS

## Preparations

- Make sure that you always have first aid equipment at hand when using the machine.
- Make sure nobody else is in the vicinity of the machine when you start the engine, engage the drive or run the machine.
- Make sure animals and people maintain a safe distance from the machine.
- Clear the area of objects such as stones, toys, steel wire, etc. that could become caught in moving machine parts and thrown out.
- Find and locate all fixed objects in the ground, such as sprinkler systems, poles, water valves, bases for washing lines, etc. Be certain to check for hidden electrical cables or similar in the surface of the lawn. Always run the machine around these objects. Never intentionally run the machine over foreign objects.
- Make sure all guard plates and protective cowlings are in place and intact when using the machine.
- Make sure no clothing, long hair or jewelry can catch in moving machine parts.
- Never use the machine when barefoot. Always wear protective shoes or protective boots with anti-slip and preferably with steel toes.
- Wear approved ear-protection when running the machine. Ask your dealer about approved ear-protection.



### WARNING!

Always use approved protective clothing and approved protective equipment when using the machine. Protective clothing and protective equipment cannot eliminate the risk of accidents, but wearing proper clothing and the correct equipment will reduce the degree of injury should an accident occur. Ask your dealer about approved protective clothing and approved protective equipment recommended by Husqvarna.

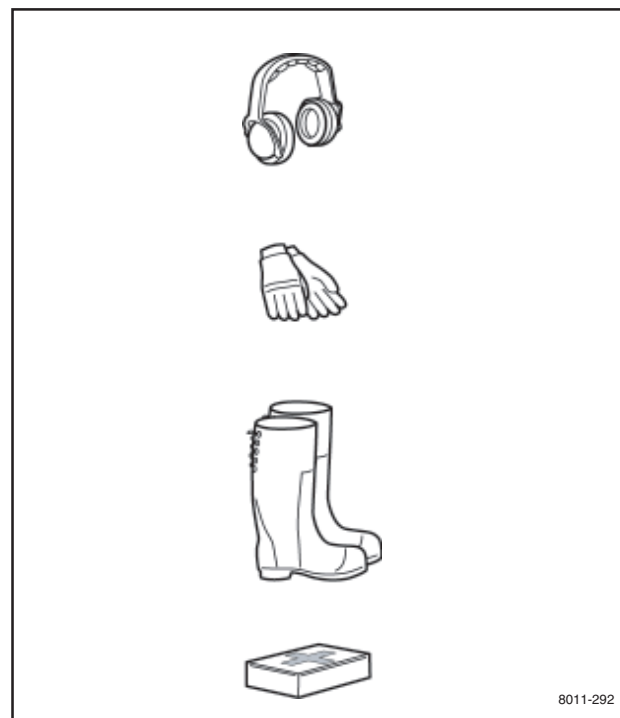
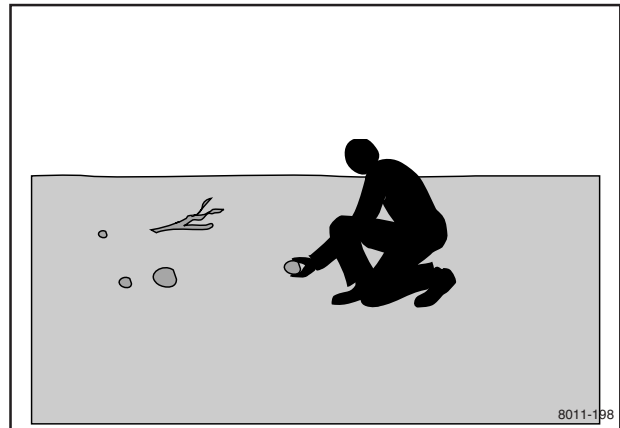

# SAFETY INSTRUCTIONS

## Running

- Do **not** use the machine on grades of more than 20°. We recommend working across slopes rather than up and down. This will yield a more even result. Do **not** leave the machine standing on a slope unattended.
- Do **not** use the machine if you are tired, if you have consumed alcohol, or if you are taking other drugs or medication that can affect your vision, judgment or coordination.
- Never use the machine indoors or in spaces lacking proper ventilation.
- Do not use the machine on any surface other than grass.
- Make sure you have a proper foothold when using the machine, particularly when backing. Walk, don't run. Never work on wet grass. Poor traction may cause you to slip.
- Keep your hands and feet away from moving parts.
- Keep your hands and feet away from the work tools.
- Slow down and be especially careful on slopes. Make sure to run the machine in the recommended direction on slopes. Be careful when working close to sudden changes in level.
- Smoking, open flames or sparks in the vicinity of the machine are **strictly** forbidden. Gasoline is extremely flammable and carelessness in handling can result in personal injury or fire.
- Stop and inspect the equipment if you run over or into anything. If necessary, make repairs before beginning again.
- Whatever happens, you should always park the machine on even ground, disengage the drive, turn off the engine and wait until all moving parts have stopped before leaving the operating position behind the machine.



The engine exhaust is poisonous. Never run the engine indoors.



Keep your hands and feet away from moving parts.



Smoking near the machine is **strictly** prohibited.

## **WARNING!**

Engine exhaust, some of its constituents and certain vehicle components contain or emit chemicals considered to cause cancer, birth defects or other reproductive harm. The engine emits carbon monoxide, which is a colorless, poisonous gas. Do not use the machine in enclosed spaces.

# SAFETY INSTRUCTIONS

## Movement/Transport

- To turn and steer the machine, press down on the handle and turn on the back wheels.
- Turn off the engine and allow it to cool at least 2 minutes before transport.
- Collapse the handle if the machine is equipped with a collapsible handle.
- Be careful and use safe lifting and moving techniques when loading/unloading the machine.
- We recommend having two people to lift the machine.
- Fasten the machine properly in place with approved fasteners, such as tension belts, chains or rope. Always check that you are in compliance with applicable traffic regulations before transporting the machine.

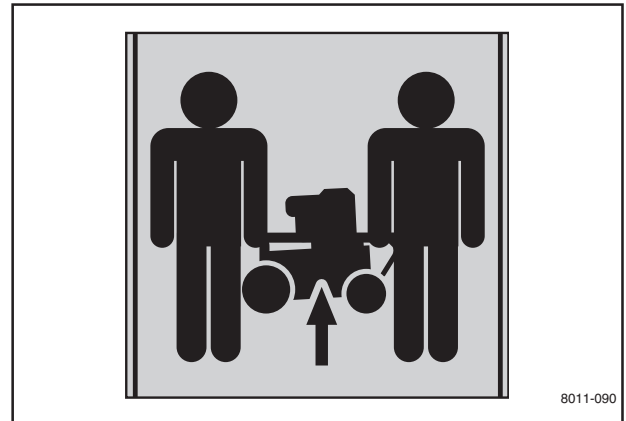

*We recommend having two people to lift the machine.*

## Storage

- Allow the engine to cool before storing the machine. Never store the machine near a open flame.
- Store the machine with the fuel valve closed.
- Store the machine and fuel in such a way that there is no risk that leaking fuel or fumes can come in contact with flames or sparks from electrical machines, electric engines, relays, switches, boilers or similar.
- Store the machine in a locked space away from children and adults untrained in use of the machine.

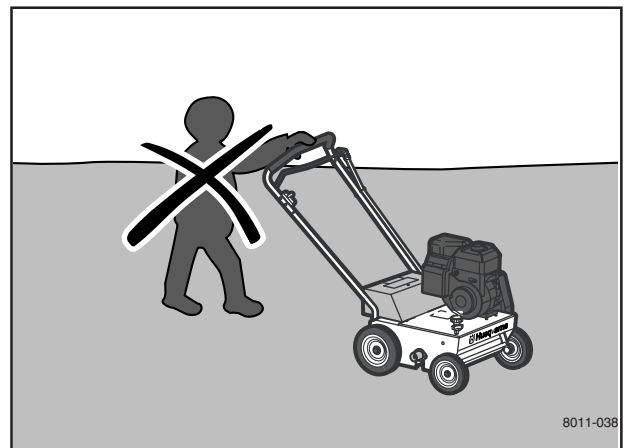

*Keep children away from the machine.*

## Children

Serious accidents can occur if you fail to be on guard for children in the vicinity of the machine. Never assume that children will stay put where you last saw them.

- Keep children away from the machine.
- Keep children away from the work area and under close supervision by another adult.
- Keep an eye out and shut off the machine if children enter the work area.
- Never allow children to operate the machine.
- Be particularly careful near corners, bushes, trees or other objects that block your view.

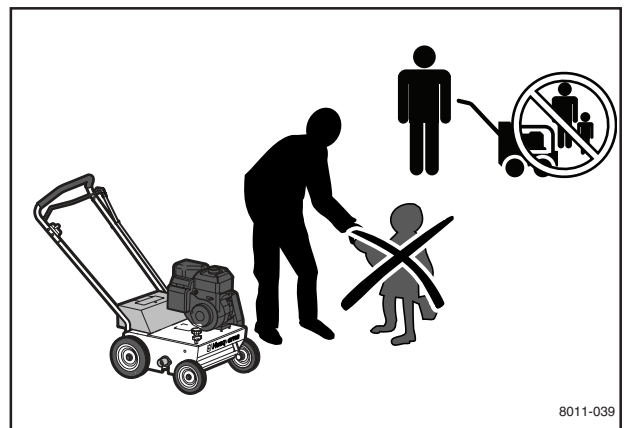

*Keep children away from the work area.*

# SAFETY INSTRUCTIONS

## Fuel system



### WARNING!

Gasoline and gasoline fumes are poisonous and extremely flammable. Be especially careful when handling gasoline, as carelessness can result in personal injury or fire.

- Only store fuel in containers approved for that purpose.
- Never remove the fuel cap and fill the fuel tank when the engine is running.
- Always stop the engine when refueling.
- Do not smoke when filling the gasoline tank and do not pour gasoline in the vicinity of sparks or open flame.
- Never fill the fuel tank indoors.
- Before starting the machine after refueling, it should be moved at least 10 feet (3 M) from the location where it was filled.
- Turn off the fuel supply for storage or transport.
- If leaks arise in the fuel system, the engine must not be started until the problem has been resolved.
- Check the fuel level before each use and leave space for the fuel to expand, because the heat from the engine and the sun can otherwise cause the fuel to expand and overflow.
- Avoid overfilling. If you spill gasoline on the machine, wipe up the spill and wait until it has evaporated before starting the engine. If you spill gasoline on your clothing, change your clothing.



Never fill the fuel tank indoors.

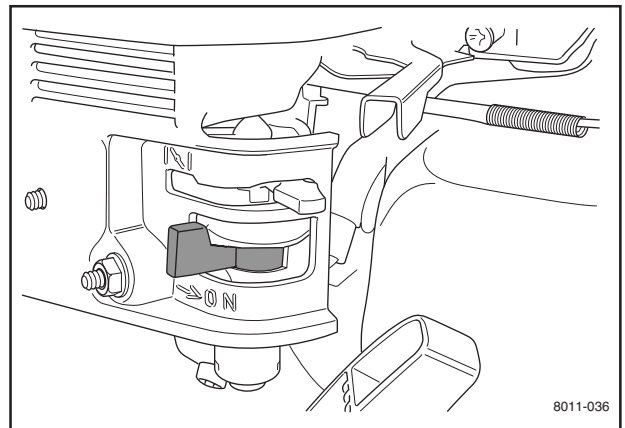

Close the fuel valve.



Fueling always poses an element of risk.

# SAFETY INSTRUCTIONS

## Maintenance

- Never make adjustments with the engine running.
- Disengage the drive units, shut off the engine and wait until all moving parts come to a complete stop before making adjustments, performing maintenance or cleaning the machine.
- Disconnect the spark plug cable before beginning repair work.
- Keep all components in serviceable condition and make sure all nuts, bolts, etc. are tight. Replace worn or damaged decals.
- Be careful when checking work tools. Use gloves when performing maintenance work.
- Never allow persons not trained in the use of the machine to perform service on it.
- Always park the machine on even ground before performing maintenance or making adjustments.
- Do not disassemble the engine. This can invalidate your guarantee. Contact your dealer if you have any questions regarding service or guarantee matters. Follow all maintenance instructions.
- Do not change the setting of governors and avoid running the engine with overly high RPMs. If you run the engine too fast, you risk damaging the machine components.
- Do not modify safety equipment. Check regularly to be sure it works properly. The machine must not be run with defective or disassembled safety equipment.
- The muffler is designed to maintain sound levels at an approved level and keep direct exhaust away from the user. Exhaust gases from the engine are extremely hot and may contain sparks that can cause fires or burn the user.
- Never use a machine with a defective muffler.
- Reduce the risk of fire by removing grass, leaves and other debris that may have caught in the machine.

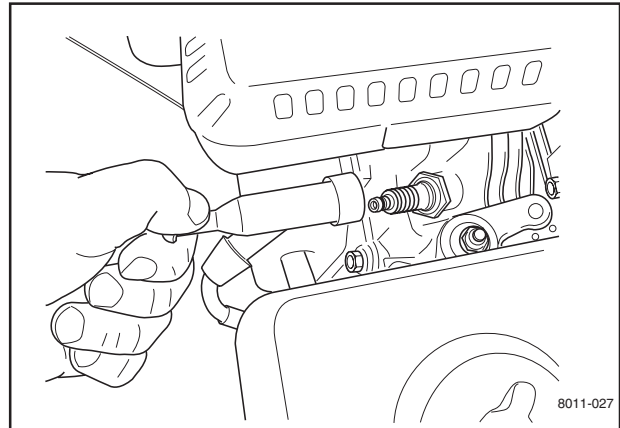

*Disconnect the spark plug cable before repair work.*



### **WARNING!**

**Wait until all moving parts are completely still before performing maintenance on the machine.**

**Turn off the engine and remove the spark plug cable.**



*Keep the machine clean.*

---

# PRESENTATION

---

## Presentation

Congratulations on your choice of an exceptionally high quality product. This operator's manual describes the Husqvarna dethatcher. The machine is available in one basic design—DT22.

The machine is equipped with a 5.5 hp Honda four-cycle engine.

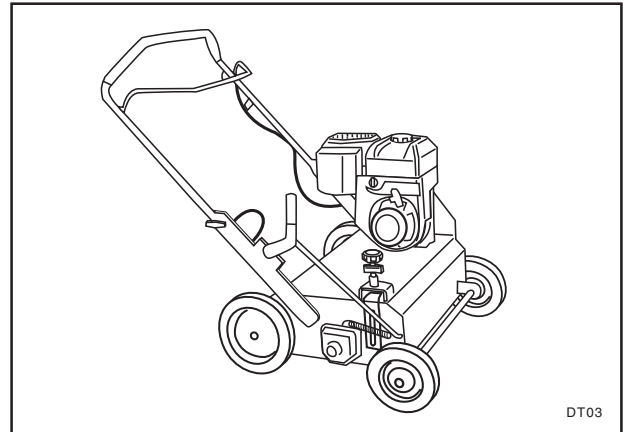

DT22 can be equipped with a catcher. It is available as an accessory at your Husqvarna dealer. It can be mounted aftermarket; see the chapter "Assembly instructions/Assembly directions, catcher bag

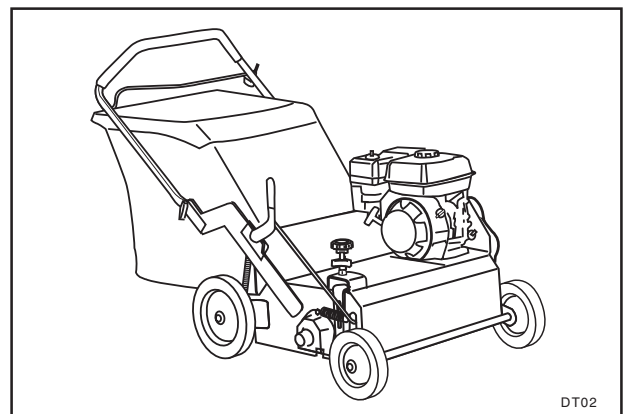

Alternatively, DT22 can be equipped with a seeder. It is available as an accessory at your Husqvarna dealer. It can be mounted aftermarket; see the chapter "Assembly instructions/Assembly directions, seed hopper SD22".

It is not possible to use a catcher and seeder simultaneously.

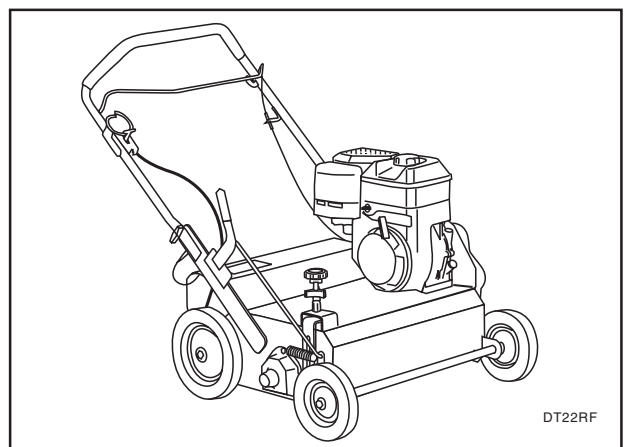

---

# PRESENTATION

---

## Main components and operating instruments

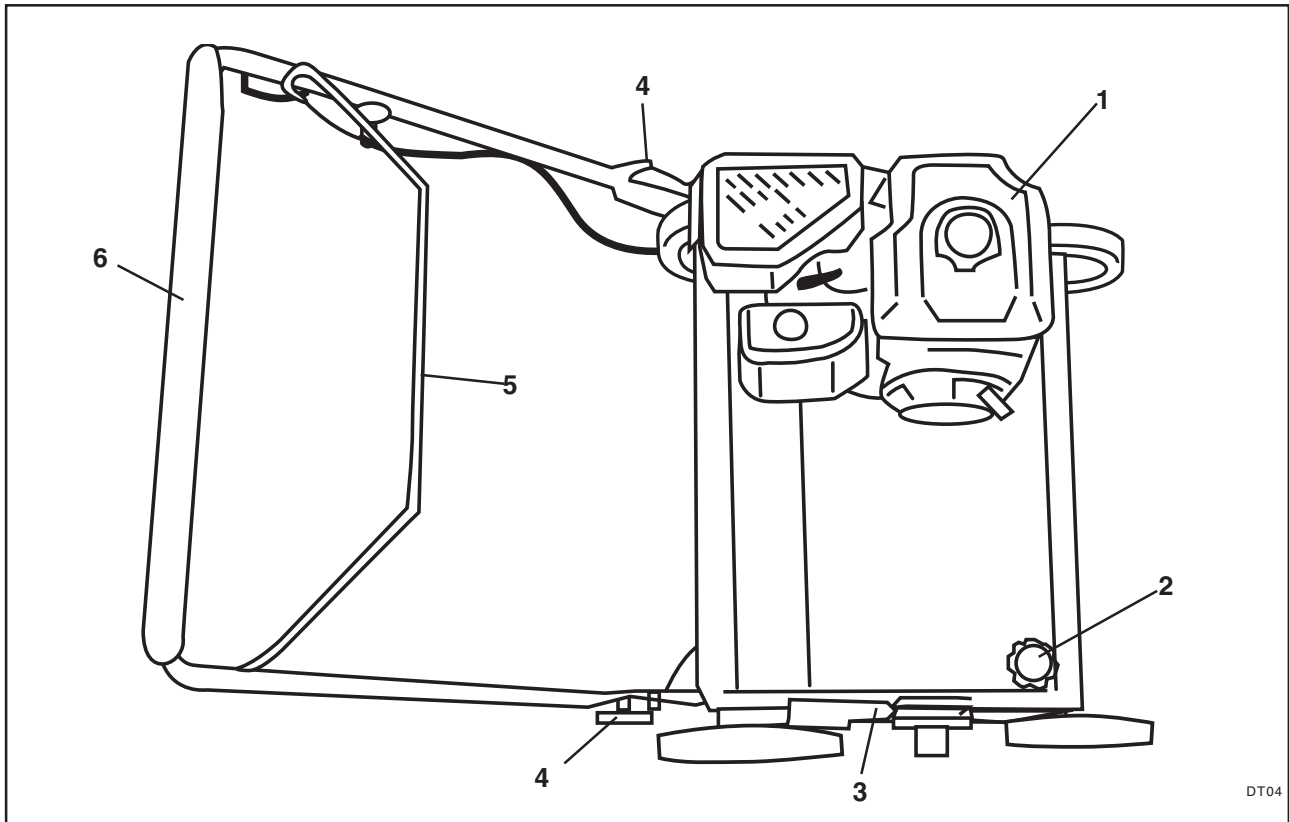

- |                               |                                |
|-------------------------------|--------------------------------|
| 1. Engine                     | 4. Knob for collapsible handle |
| 2. Depth knob with depth lock | 5. Clutch bail                 |
| 3. Depth lever                | 6. Handle                      |

# PRESENTATION

## Engine

Exterior engine components and operating instruments

1. Throttle control
2. Starter
3. Starter handle
4. Fuel valve
5. Choke
6. Air filter
7. Spark plug
8. Muffler
11. Oil dipstick engine
12. Oil drainage engine
13. Oil level meter
14. Engine switch
15. Fuel tank
16. Fuel filler cap

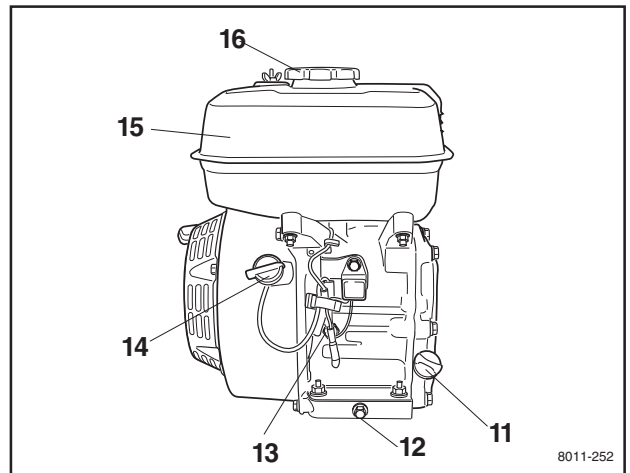
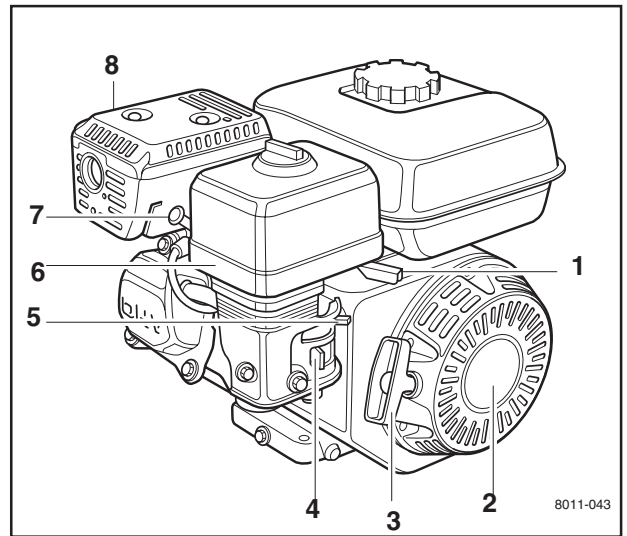

## Throttle control

The lever controls engine speed.

The image shows half throttle. Turning the lever to the left increases throttle and to the right decreases throttle.

Turning the lever completely to the right puts the engine at idle. If the engine stalls in idle, the idle speed can be adjusted; see the chapter "Maintenance/Idle adjustment".

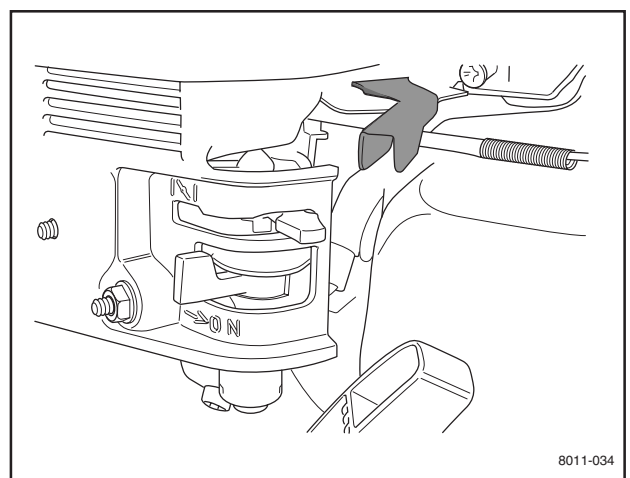

---

# PRESENTATION

---

## Starter

The starter is of the magnapull type with spring return. To replace the return spring or starter cord, contact an authorized service workshop.

## Starter handle

Misuse of the starter handle can damage the starter. Never twist the starter cord around your hand.

Pull out the handle slowly until the gears mesh. Do not pull out the starter cord completely and do not let go of the starter handle when extended.

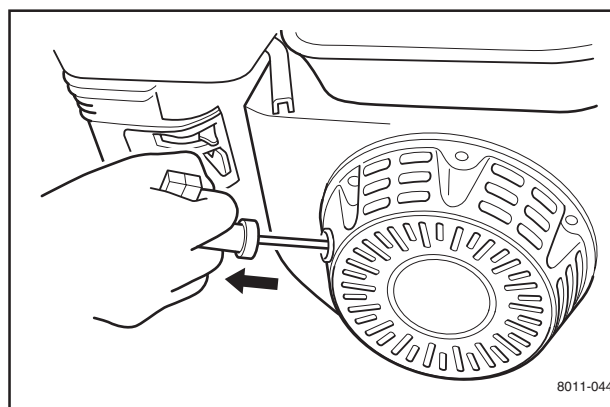

## Fuel valve

The fuel valve opens and closes the connection between the tank and the carburetor.

The illustration shows the tank valve closed; to open, turn the lever completely to the right. There is no middle position.

Turn off the valve when the machine is not in use to avoid flooding the carburetor.

The fuel valve is combined with a sludge reservoir. For cleaning instructions see the chapter "Maintenance/Cleaning the sludge reservoir".

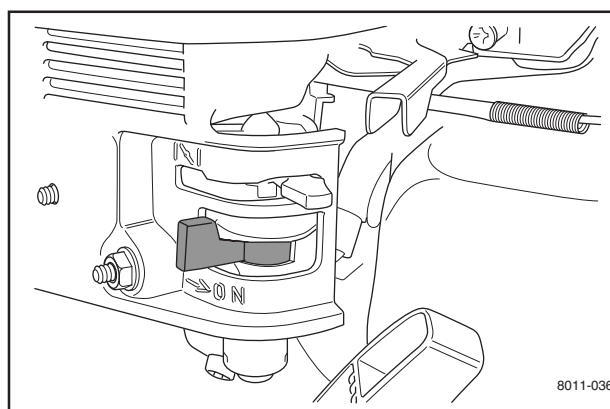

## Choke

The choke opens and closes the choke valve in the carburetor. This is only used to start a cold engine.

The image shows the choke valve open; to close, turn the lever to the left. The midway positions can be used. When the engine starts, the lever can be turned gradually to the right as long as it continues to run smoothly. Forgetting the choke is evident as the engine runs roughly and produces black smoke.

This also results in increased fuel consumption.

## Air filter

The engine air filter is located under the cowling. It consists of a foam rubber pre-filter and a paper filter cartridge. See the chapter "Maintenance/Air filter replacement" for cleaning instructions. Running the machine with a dirty air filter will cause the engine to run on partial choke and show the same symptoms as a forgotten choke described above. It can also be difficult to start.

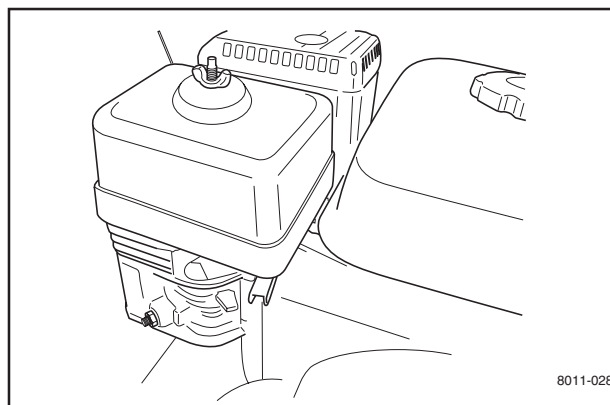
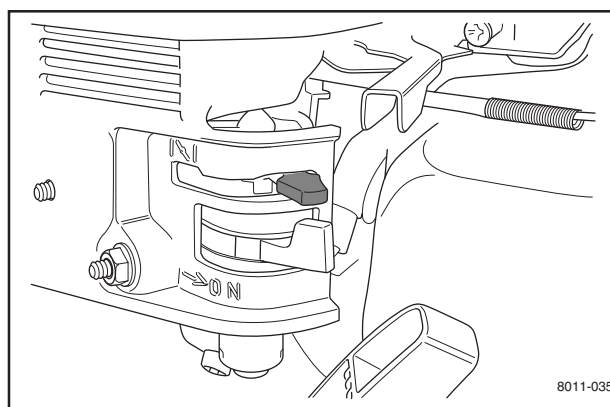

# PRESENTATION

## Spark plug

The engine spark plug is hidden under the ignition cable shoe. When performing service, it is important that the engine cannot start accidentally. For this reason, always remove the ignition cable shoe from the spark plug. To avoid pulling the cable, the cable shoe is equipped with a special handle; see the illustration.

Type of spark plug, see chapter "Technical data".

Service instructions, see chapter "Maintenance/ Ignition system".

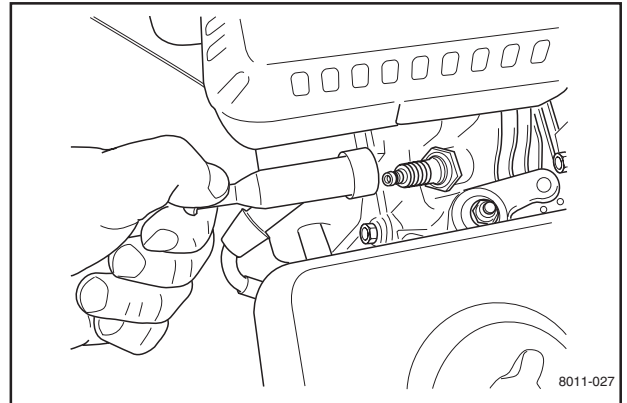

## Muffler

The engine muffler is equipped with a heat protective cowling. Nonetheless, it still becomes hot when the engine is running. Avoid touching the muffler when it is warm. Risk for burns.

## Oil dipstick

The dipstick for the crankcase oil reservoir is located on the front of the engine. Refill the engine oil in the hole where the dipstick fits.

When checking the oil level, the dipstick should **not** be screwed in. The machine should be parked on even ground with the engine stopped. Never run the engine without the dipstick in place. The engine has an electronic oil level guard. It stops and cannot be started if the level becomes too low. Yet you should not rely entirely on the level guard; rather you should check the oil using the dipstick.

For normal use, we recommend SAE 10W-30-weight engine oil service SF-SG; see also the chapter "Lubrication/Engine oil".

## Oil drainage

The drainage screw for the crankcase oil reservoir is located on the front of the engine.

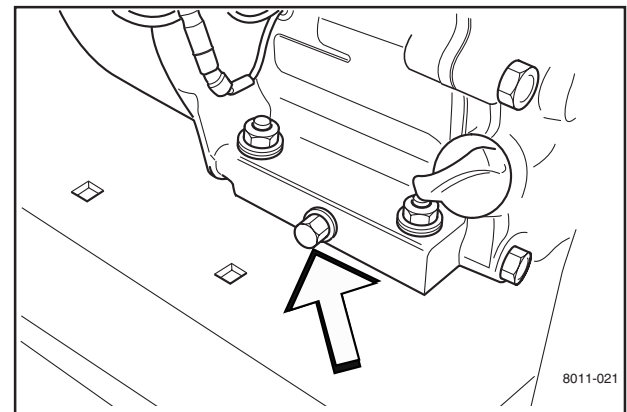
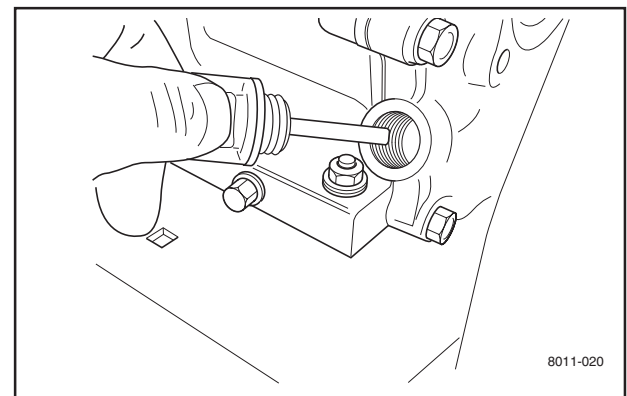

### IMPORTANT INFORMATION

**Used engine oil is a health hazard and legislation prohibits disposal on the ground or in nature; it should always be disposed of at a workshop or appropriate disposal location. Avoid skin contact; wash with soap and water in case of spills.**

## Engine switch

The engine switch stops the engine. The illustration shows the switch in the OFF position (short circuited electrical system). To start the engine, the switch must be first set to the ON position.

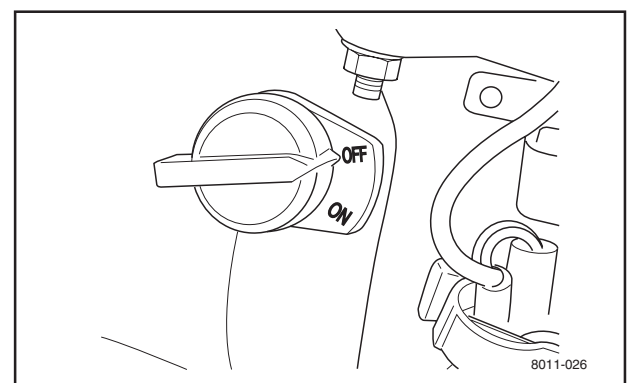

---

# PRESENTATION

---

## Fuel tank

Underneath the tank, there is a fuel filter combined with the fuel valve. The tank can be filled with 3.6 liters/0.95 US Gal for the DT22.

## Fueling

Read the safety instructions before fueling. Keep the fuel and fuel tank clean. Avoid filling the machine with dirty fuel. Make sure the fuel cap is properly tightened and the gasket is not damaged, particularly before washing the machine.

Use unleaded gasoline with minimum 86 octane rating. Never use gasoline mixed with two-cycle oil. For ethanol and methanol fuel, the following applies:

Maximum allowable ethanol 10% (volume).

Maximum allowable methanol 5% (volume).

Maximum allowable MTBE (Methyl Tertiary Butyl Ether) 15% (volume).

If the engine "bolts" at normal load it can be damaged. Change the fuel. If this does not help, contact an authorized service workshop.

Do not fill the tank completely; leave space for the fuel to expand as it warms up.

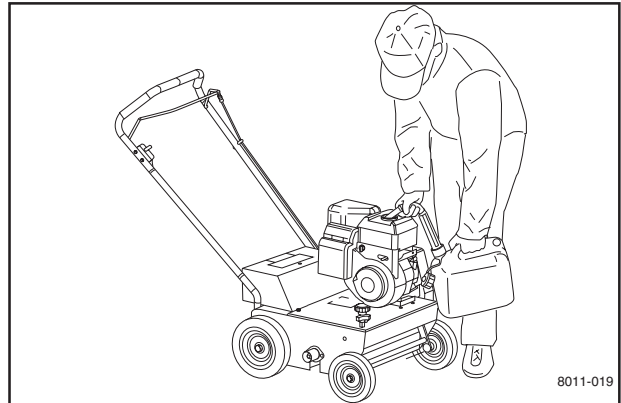

## WARNING!

**Gasoline is highly flammable. Observe caution and fill the tank outdoors.  
(See the safety instructions.)**

---

# PRESENTATION

---

## Cutting unit

### Depth lever

Use the depth lever to raise and lower the blades between working and transport position. When the lever is up, the blades are in working position. Blades should penetrate the soil to a depth of 1/8" to 1/4" with a maximum penetration of 1/2". Check your seed bag for the manufacturer's recommended depth of application.

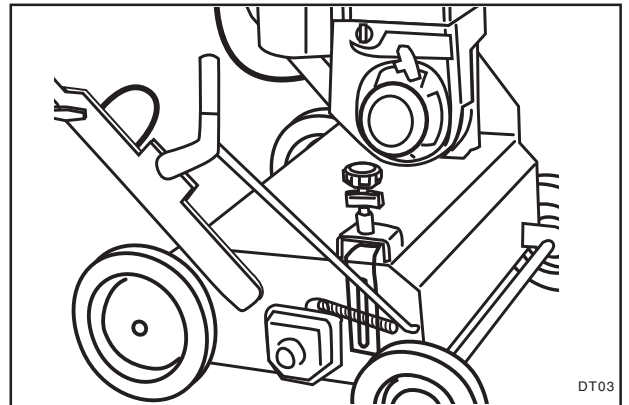

### Depth knob

The knob is used to adjust the cutting depth of the blades. Turning the knob counterclockwise increases the working depth. A shim has been added at the factory to keep the blades from penetrating the soil too deeply. As the blades wear, remove the shim and store below the depth lock until new blades are added, then replace the shim in the original position.

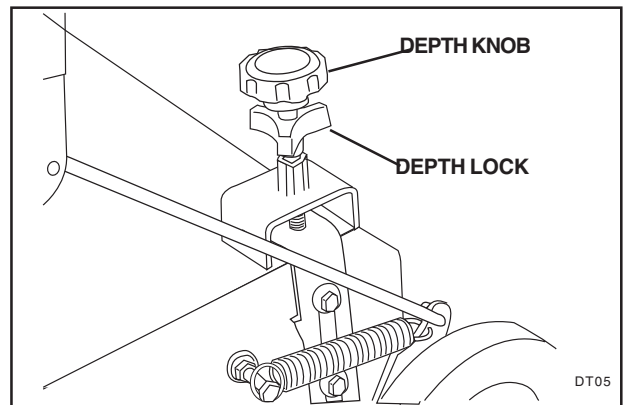

### Depth lock

The screw under the depth knob is used to lock the depth knob to prevent it being changed by machine vibrations. Undo the depth lock by turning it counterclockwise before turning the depth knob. Secure the depth knob with the depth lock after adjusting settings.

### Clutch

The clutch tightens the drive belt and engages the drive for the blades. When the clutch lever is pressed against the handle, the blades begin to rotate. Hold the clutch tightly when working so that the belt does not slide.

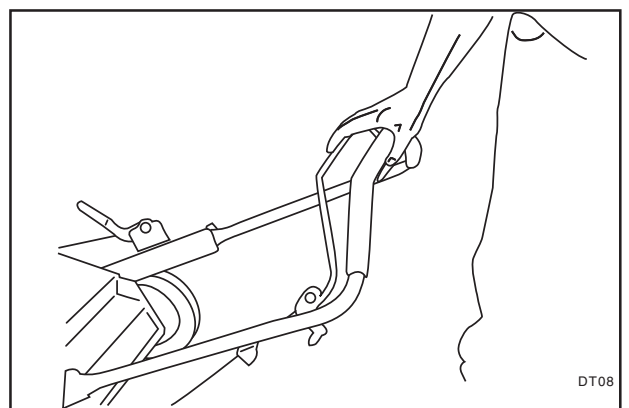

---

# PRESENTATION

---

## Blade versatility

### Flail blade

Thatch is the dense layer of clippings, roots and stems that forms between the soil and the base of the grass. As thatch builds up, it prevents water, air and fertilizer from being absorbed into the soil. This causes shallow root development leading to vulnerability to drought and frost. Excessive thatch also creates an ideal environment for insects and lawn diseases. Power-raking with flail blades removes this thatch layer and restores your lawn to good health. Flail blades offer the most aggressive dethatching of all the blades offered.

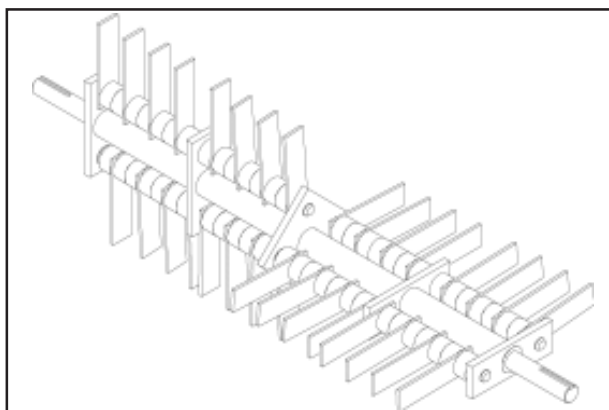

### Delta blade

Delta blades were created primarily for overseeding existing lawn. They effectively incorporate grass seed into the soil. This is an easy, reliable method for rejuvenating poor lawns. The delta blade is also useful as a vertical mower for cutting running stem grasses and opening up the soil to oxygen, water, nutrients and other chemicals. Delta blades are also beneficial on slopes, terraces and in high clay content soils where water runoff is a problem. Blades should penetrate the soil to a depth of 1/8" to 1/4" with a maximum penetration of 1/2". Check your seed bag for the manufacturer's recommended depth of application.

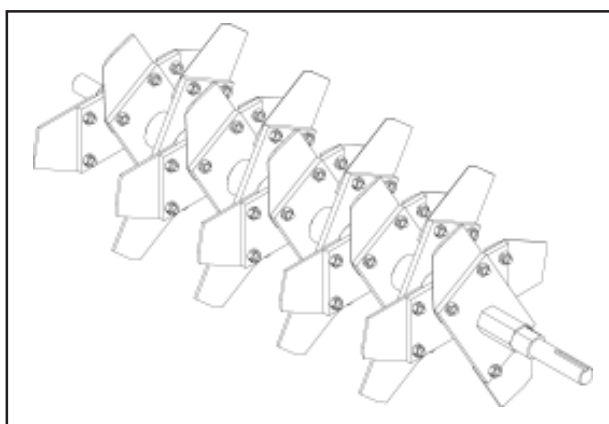

### Spring tine

Ideal for the established lawn that is not in need of a complete renovation but requires dethatching (dry-spots, fungus, etc.). Spring tines are designed to pluck dead grass and thatch out of the lawn without tearing or damaging existing root structure. With the flexible tines, the lawn is combed only 0.5 cm into the soil, so it cannot penetrate the root structure. Spring tines provide less aggressive dethatching than flail blades.

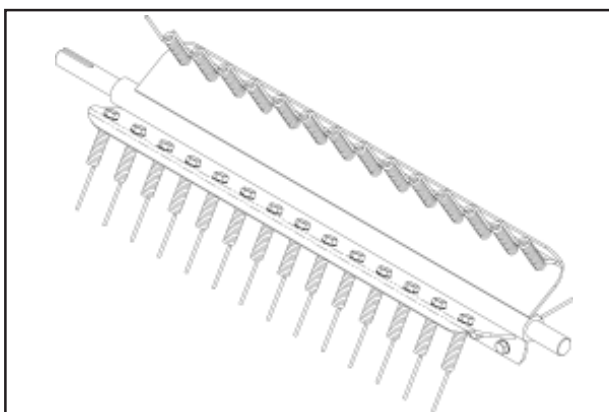

### Setting blade height

The blades are raised and lowered using a depth lever on the right side of the machine. The knob in front of the lever controls the depth. Turning the knob counterclockwise increases blade depth.

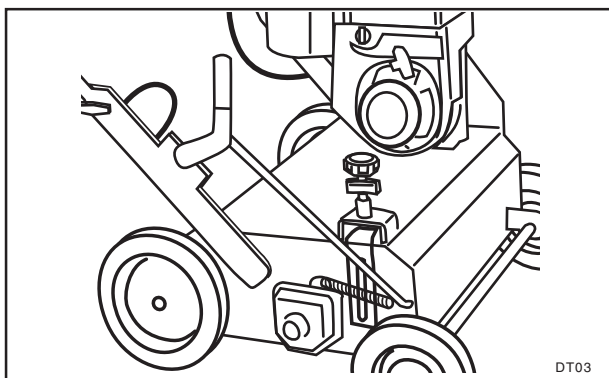

# OPERATION

## Starting the engine

Check that all daily maintenance as described in the maintenance schedule has been performed. Check that there is sufficient fuel in the tank.

## Fuel valve

Open the fuel valve. Turn the lever all the way to the right.

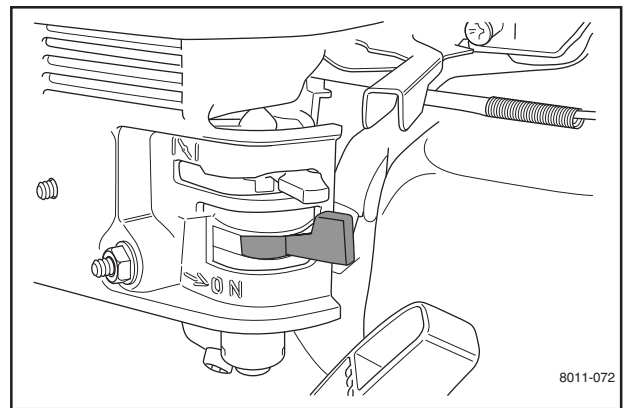

## Choke

When starting the engine warm, the lever should be in the right position; see the illustration.

When starting the engine cold or partially warm, turn the lever completely or partly to the left.

Move the lever back to the right once the engine starts. When the engine is cold, it may be best to move the lever back in several stages. Find the position where the engine runs smoothly.

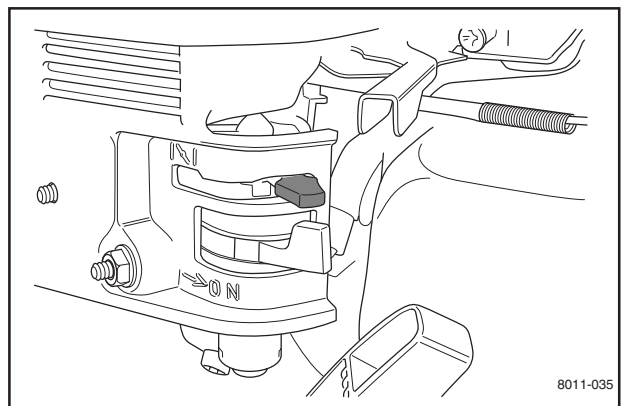

## Throttle control

Set the throttle with about 1/3 of full throttle from idle. This means 1/3 of the way from the rightmost end stop.

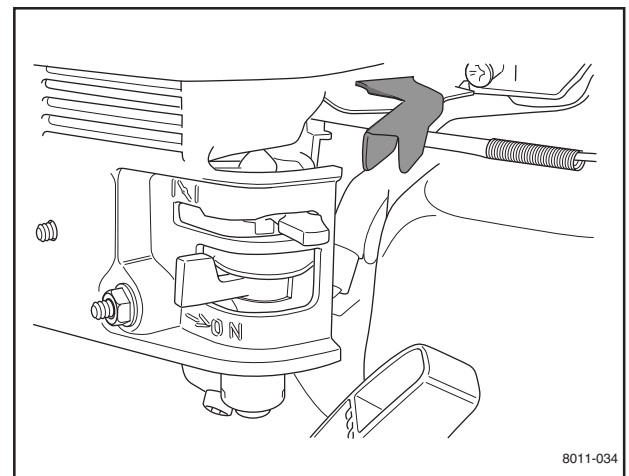

## Engine switch

Turn the engine switch clockwise to ON.

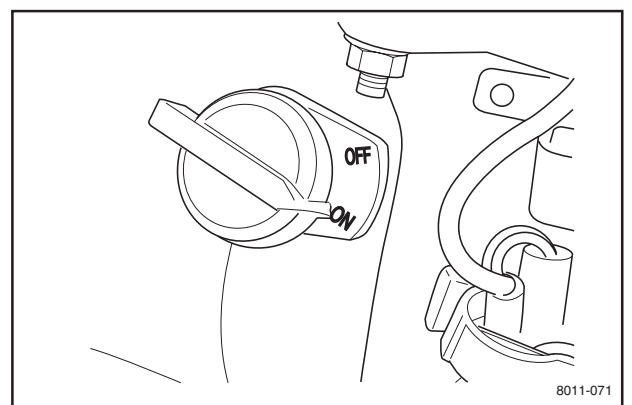

# OPERATION

## Starter handle

Misuse of the starter handle can damage the starter. Do not twist the starter cord around your hand.

Pull out the handle slowly until the gears mesh. Then give a sharp pull on the starter handle. Do not pull out the starter cord completely and do not let go of the starter handle when extended.

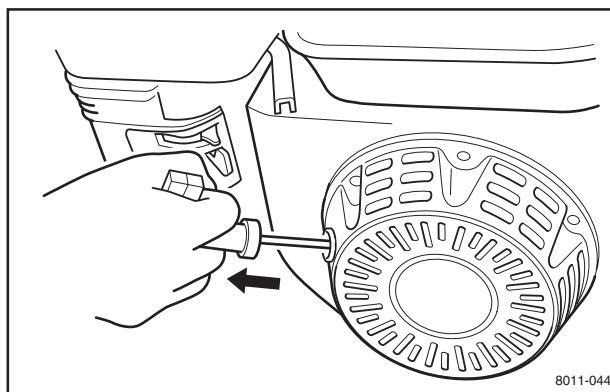

## Throttle control

Adjust the engine speed with the throttle. Moving the lever to the left increases throttle and to the right decreases throttle.

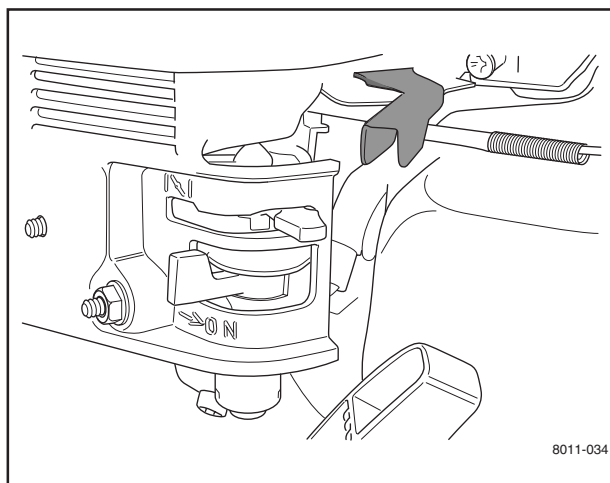

## Cutting the engine

If the engine has been running full out, let it run easily for about 30 seconds to 1 minute at low speed.

## Engine switch

Turn the engine switch counterclockwise to OFF.

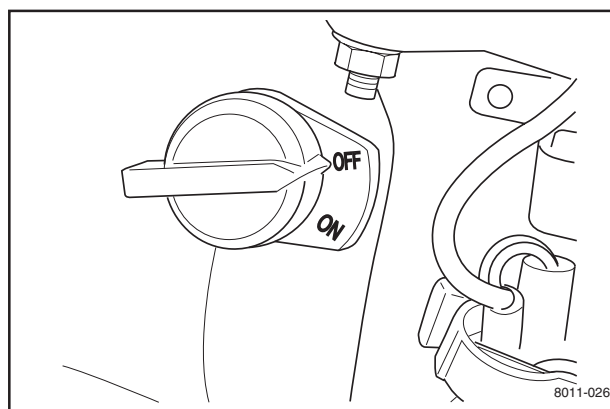

## Fuel valve

Close the fuel valve. Turn the lever all the way to the left (see illustration).

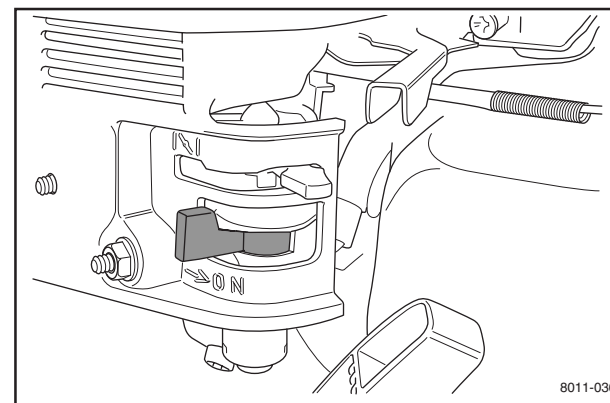

# OPERATION

## Before you start

- Mow the lawn 1/2" shorter than normal.
- Allow the lawn to dry. Wet conditions can cause extensive damage to healthy grass.

## FLAIL BLADES OR SPRING TINES:

- **Flail Blades or Spring Tines:** Set blade or tine depth so that the blades or tines just touch on a flat surface such as a sidewalk or driveway.
- **Delta Blades:** Set blades to penetrate the soil to a depth of 1/8" to 1/4" with a maximum penetration of 1/2". Check your seed bag for the manufacturer's recommended depth of application
- Lawns with deep thatch exceeding 2 cm may be best dethatched in two treatments (spring and fall) to avoid major shock to an older lawn.

## Starting

- Set the depth lever in working position.
- To engage the clutch in heavy thatch, bear down on the handle and raise the front wheels slightly. Hold the clutch engaged against the handle and carefully lower the machine into the turf.
- Do a small test area at a slow walking pace.
- If the engine speed drops excessively, the depth setting is too deep. Turn the depth knob clockwise.
- If the machine pulls forward and bucks roughly, the depth setting is too deep. Check for stones or fixed objects in the lawn. Then turn the depth knob clockwise.
- Lock the depth knob with the depth lock after adjusting settings.

## Finishing

- Remove all extracted thatch from the grass and compost/dispose of properly.
- Other methods for improving your lawn may include aeration and fertilization.

### IMPORTANT INFORMATION

**Clear the lawn of any debris.**

**Clearly mark rocks and other fixed objects.**

**Be especially sure to check for hidden electrical cables or similar in the surface of the lawn.**

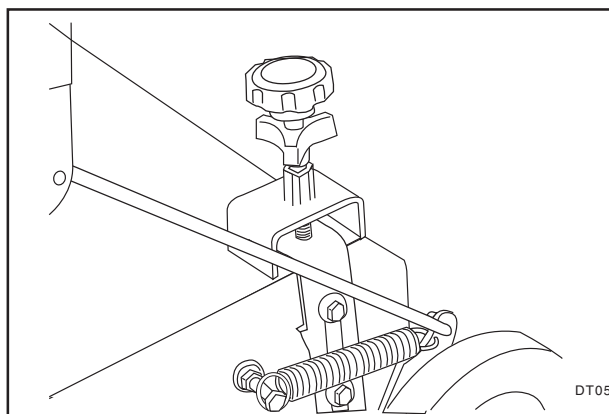
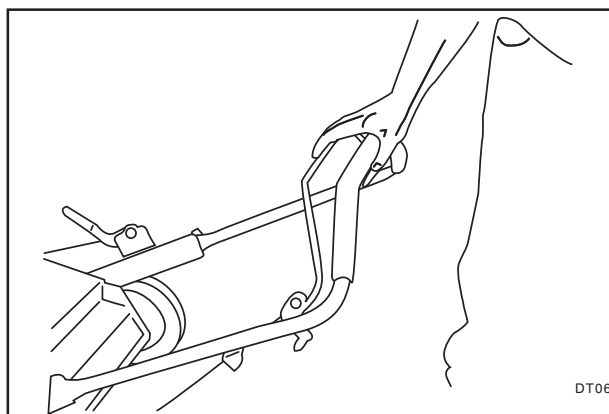
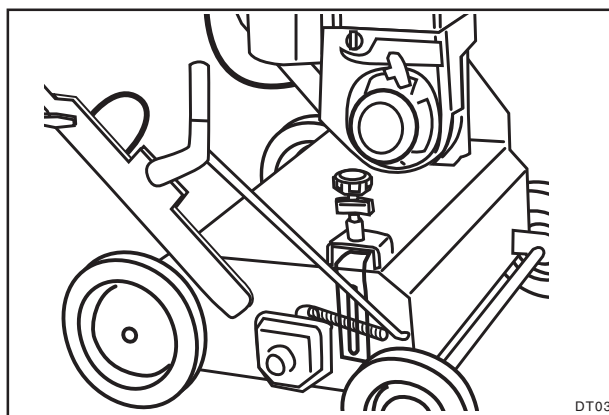

# MAINTENANCE

## Maintenance schedule

The following is a list of maintenance procedures that must be performed on the machine. For those points not described in this manual, visit an authorized service workshop.

Maintenance	Page	Daily maint. before starting	Maintenance interval months/hours			
			1/25	3/50	6/100	12/300
Check the engine oil level	34	●				
Replace engine oil <sup>1)</sup>	34				●	
Check the air filter	25	●				
Clean the air filter <sup>2)</sup>	25			●		
Replace air filter cartridge <sup>2)</sup>	25					●
Clean sludge reservoir for fuel system	26				●	
Check and clean the spark plug	27				●	
Replace the spark plug	27					●
Check idle speed	26					●
Check and adjust play in valves <sup>4)</sup>	-					○
Clean fuel tank <sup>4)</sup>	-					○
Check, replace fuel lines as necessary <sup>4, 5)</sup>	-					○
Check clutch and clutch cable	-	○				
Check flail blade lock washers	-	○				
Check decals and warning signs	-	○				
Check the seed holes for the seeder	-	○				
Check wear and tension on the belts	28		●			
Check blade wear and condition	29		●			
Check the chassis, bolts and set screws	-			○		
Check the seed control lever for the seeder	-		○			
Check the wire mountings on the seeder	-		○			
Lubrication; see the Lubrication schedule						

<sup>1)</sup> First change after 20 hours. <sup>2)</sup> In dusty conditions maintenance is required at shorter intervals. <sup>3)</sup> With daily use, the machine shall be lubricated twice weekly. <sup>4)</sup> Performed by authorized service workshop. <sup>5)</sup> Performed every second year.

● = Described in this manual.

○ = Not described in this manual.



### WARNING!

**No service operations may be performed on the engine or unit unless:**

- The engine is stopped.
- The ignition cable has been removed from the spark plug.
- The machine is securely parked where it will not tip or begin rolling.

# MAINTENANCE

## Replacing the air filter

If the engine seems weak, produces black smoke or runs unevenly, the air filter may be clogged.

For this reason, it is important to clean and replace the air filter regularly (see the maintenance schedule for the proper service interval).



### WARNING!

**Allow the exhaust system to cool before performing service. Risk for burns.**

Cleaning/replacement of the air filter is carried out as follows:

1. Undo the wing nut and lift off the air filter cowling.
2. Remove the foam rubber pre-filter and clean using a mild detergent.  
Squeeze it dry with a clean cloth.  
Soak it with new engine oil. Wind the filter in an absorbent cloth and squeeze out excess oil.
3. Remove the wing nut in the air filter and remove the paper filter. Tap the paper filter against a fixed surface to remove dust. If the paper filter is still dirty or damaged, it must be replaced.

### IMPORTANT INFORMATION

**Do not use compressed air over 2 bar/30 PSI to clean the air filter.**

**Do not wash the paper filter.**

**Do not oil the paper filter.**

4. Refit the air filter as follows:  
Mount the paper filter in the air filter housing and tighten the wing nut.
5. Replace the pre-filter on the paper filter.
6. Replace the cowling over the air filter housing.

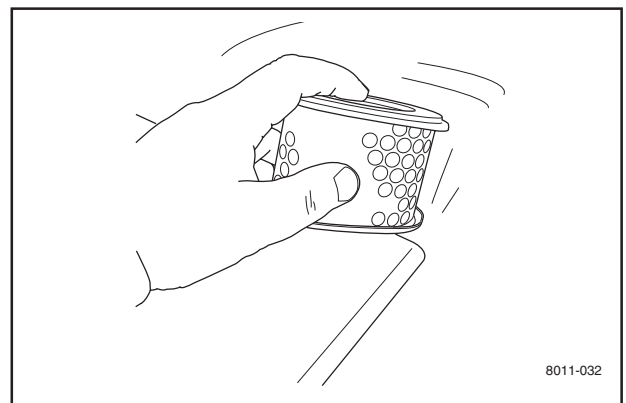
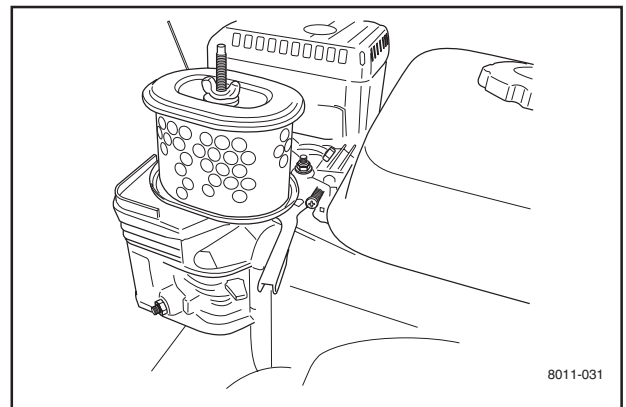
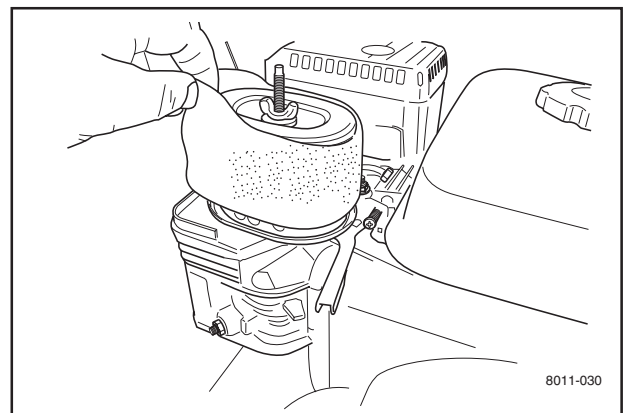
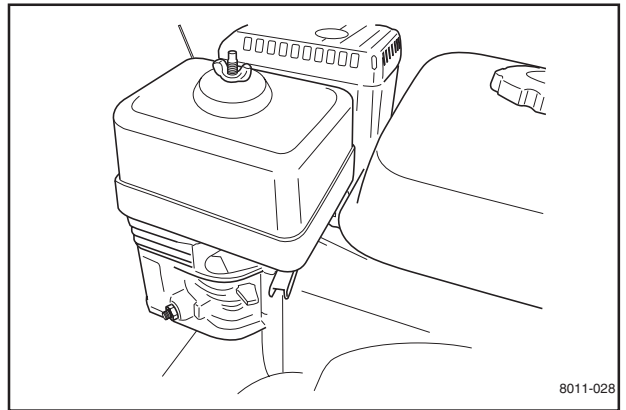

# MAINTENANCE

## Cleaning the sludge reservoir

1. Close the fuel valve.

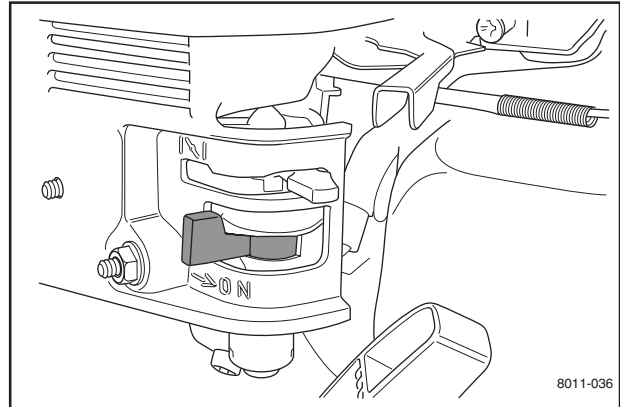

2. Unscrew the sludge reservoir (2). Make sure not to misplace the o-ring (1).
3. Clean the reservoir and the o-ring in e.g. white spirit and dry carefully.
4. Put the o-ring in place in its track and replace the sludge reservoir. Tighten it moderately to avoid damaging the threads.
5. Turn the fuel valve to ON and check for leaks. If it leaks, replace the o-ring.

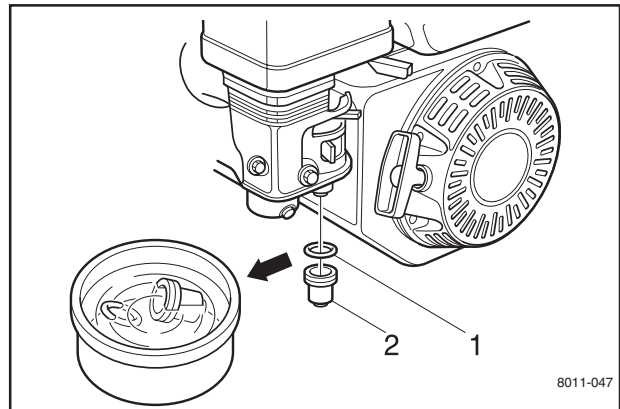

## Idle adjustment



### WARNING!

**Risk for carbon monoxide poisoning.  
Perform the adjustment outdoors.**

1. Start the engine and run it until it reaches normal working temperature.
2. Adjust the throttle to idle position or so that the engine runs at the lowest possible speed.
3. Turn the idle screw (1) so that the engine idles at 1250–1600 RPM.
4. Increase the idle speed with the throttle and move it right back to idle position. Check engine speed again.

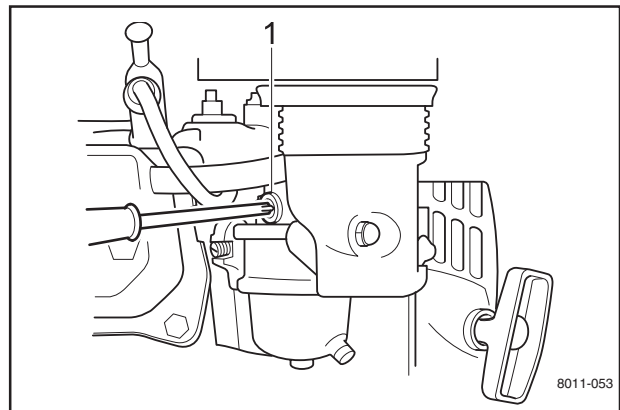

# MAINTENANCE

## Ignition system

The engine is equipped with an electronic ignition system. Only the spark plug requires maintenance.

For recommended spark plug, see chapter "Technical data".

### IMPORTANT INFORMATION

**Fitting the wrong spark plug type can damage the engine.**

1. Remove the ignition cable shoe and clean around the spark plug.
2. Remove the spark plug with a 13/16" (21 mm) spark plug socket wrench.
3. Check the spark plug. Replace the spark plug if the electrodes are burned or if the insulation is cracked or damaged. Clean the spark plug with a steel brush if it is to be reused.
4. Measure the electrode gap with a gapping tool. The gap should be 0.7–0.8 mm/ 0.028–0.031". Adjust as necessary by bending the side electrode.
5. Reinsert the spark plug, turning by hand to avoid damaging the threads.

### IMPORTANT INFORMATION

**Inadequately tightened spark plugs can cause overheating and damage the engine. Tightening the spark plug too much can damage the threads in the cylinder head.**

5. After the spark plug is seated, tighten it using a spark plug wrench so that the washer is compressed. A used spark plug should be turned 1/8–1/4 of a turn from the seated position. A new spark plug should be turned 1/2 a turn from the seated position.
6. Replace the ignition cable shoe.

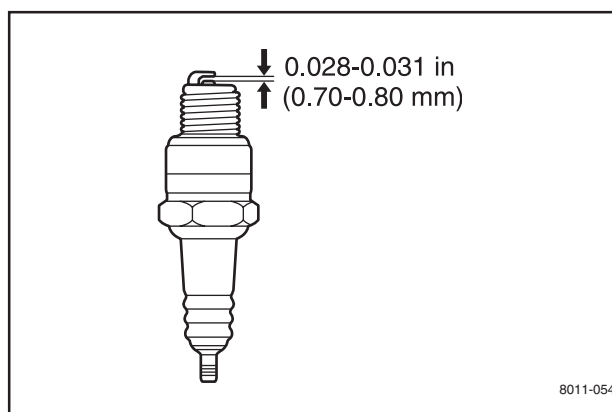
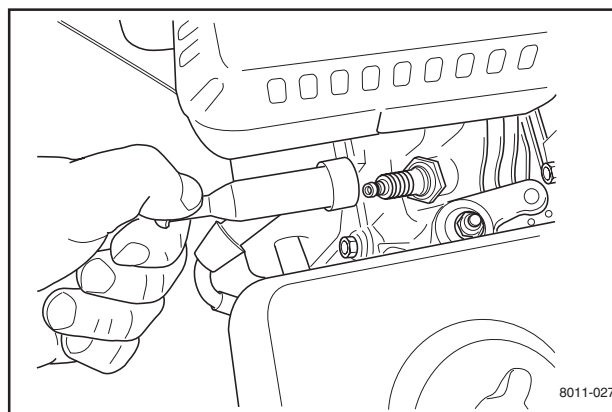

# MAINTENANCE

## Cutting unit

### Checking the drive belt

1. Allow the engine to cool.
2. Remove the spark plug cable.
3. Remove the belt guard (see illustration) on the left side of the machine.
4. Check that the belt is running in the proper track; the pulleys should guide the belt in a straight line.
5. Check that the belt and pulleys are not oily. If they are, first try to clean them with spirits. If they are heavily coated, take the machine to an authorized service workshop to fix the oil leakage and replace the belt.
6. Check the belt for cracks, heat damage or worn edges. If these symptoms appear, replace the drive belt; see "Replacing the drive belt".
7. Check that guide and tensioning equipment for the belt is not loose and is properly set; see "Replacing the drive belt".
8. Refit the belt guard.

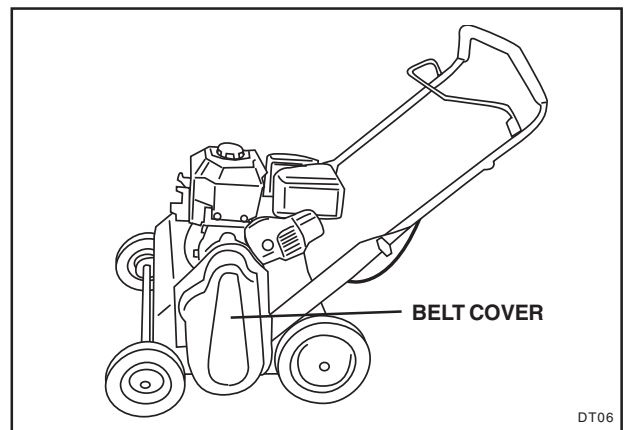
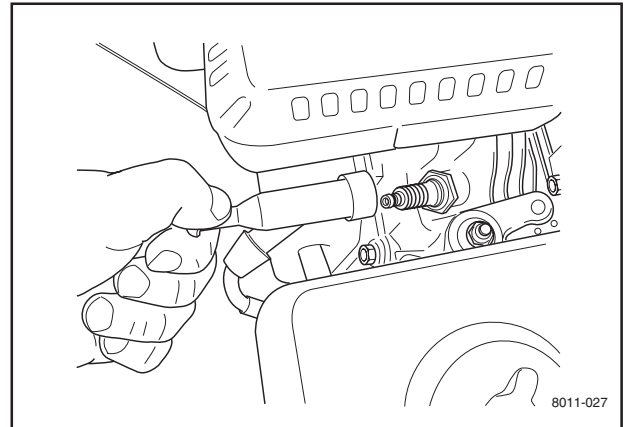

### Replacing the drive belt

Replace the drive belt as follows:

1. Allow the engine to cool.
2. Remove the spark plug cable.
3. Remove the belt guard.
4. Remove the old belt.
5. Check for wear on the pulleys and replace as necessary.
6. Check the pulley setting against the rotor pulley and adjust as necessary. The belt should run in the track.
7. Check the tensioning pulley. The bearings should rotate freely and evenly. The rocking lever on the tensioning pulley should be free with a lateral play of not more than 6.5 mm (0.25") (see illustration). Replace as necessary.
8. Fit a new belt by first pulling it over the lower pulley and then the engine pulley. Check that the tensioning pulley and belt guides end up outside the belt loop.
9. Adjust the belt guides as necessary and refit the belt guard.

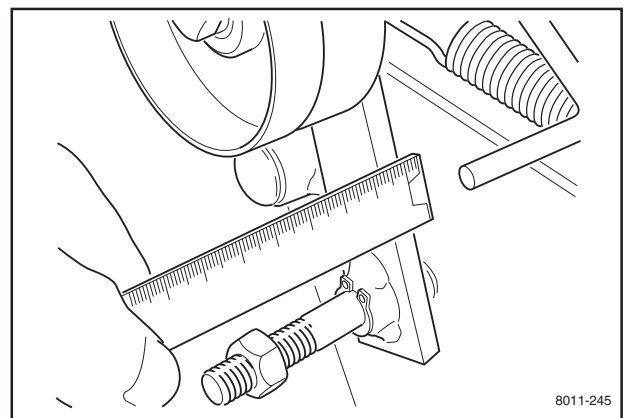
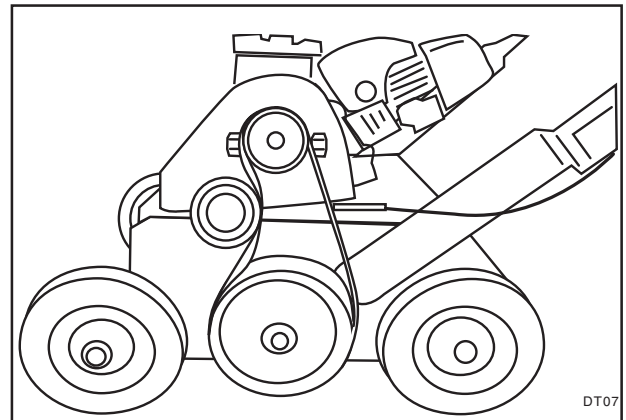

# MAINTENANCE

## Wear/Rotation/Replacing flail blades

After you have used your dethatcher for some time, the blades will begin to wear on the striking edge. When this happens, their dethatching performance will diminish. A new combing edge may be obtained by rotating the entire rotor shaft assembly laterally (end to end). This procedure can be repeated until the blades reach their wear limit; see illustration.

Rotate the rotor shaft as follows:

**IMPORTANT INFORMATION**  
Only the flail blade rotor shaft can be rotated to achieve even wear.

### Rotating the rotor shaft

1. Allow the engine to cool.
2. Disconnect the spark plug.
3. Remove the belt guard (see illustration).
4. Remove the belt guard and pulley from the rotor shaft (see illustration).
5. Remove the 6 bearing bolts and allow the rotor shaft to slide out.
6. Check the shaft, bearing, blade length, blade safety clips and spacers.
7. Rotate the shaft end for end.
8. Refit the bearing bolts.
9. Refit the pulley and check that it is aligned with top pulley.
10. Refit the drive belt.
11. Check the pulley alignment to the engine shaft pulley. The drive belt should run smoothly in its track. Adjust as necessary. Tighten the pulleys.
12. Refit the belt guard.
13. Reattach the spark plug cable.

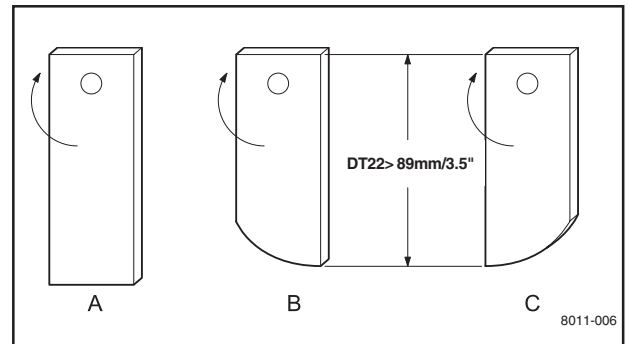

- A. New blade
- B. Worn blade
- C. After rotation

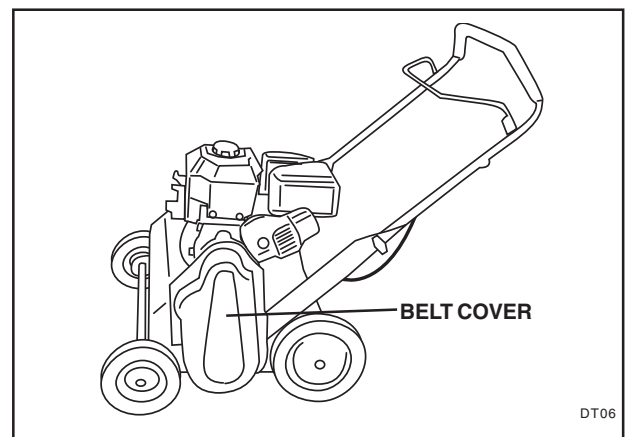
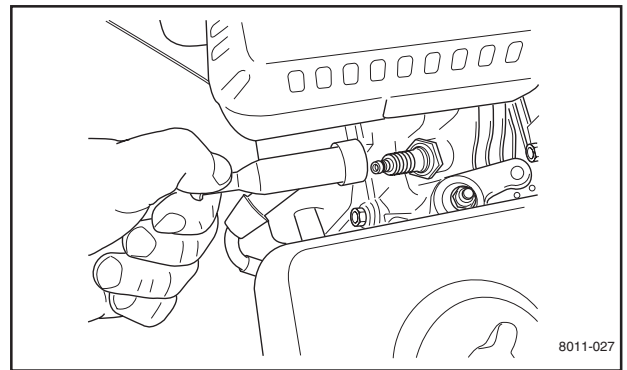

# MAINTENANCE

## Replacing worn flail blades

1. Allow the engine to cool.
2. Disconnect the spark plug.
3. Tip the machine forward; see the section "Two minute rule".

**IMPORTANT INFORMATION**  
When tipping the machine forward observe the "Two minute rule".

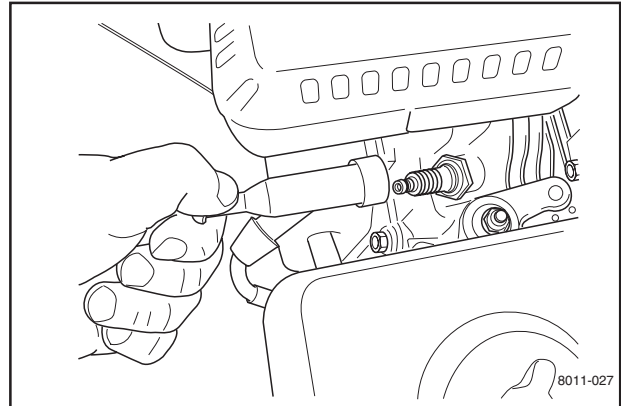

4. Remove and dispose of the spring clips (1) (locking washer type) that hold the blade shaft (2) in place (see the illustration).
5. Inspect the blade shafts and replace if bent or worn.
6. Drive the blade shafts out towards the center. The blades (4) and the plastic spacers (3) will fall off.
7. Fit the new blades and replace the plastic spacers as necessary. Refer to the illustration of the components for blade/spacer placement.
8. Install new spring clips.
9. Repeat this procedure for the remaining three shafts.
10. Reattach the spark plug cable.

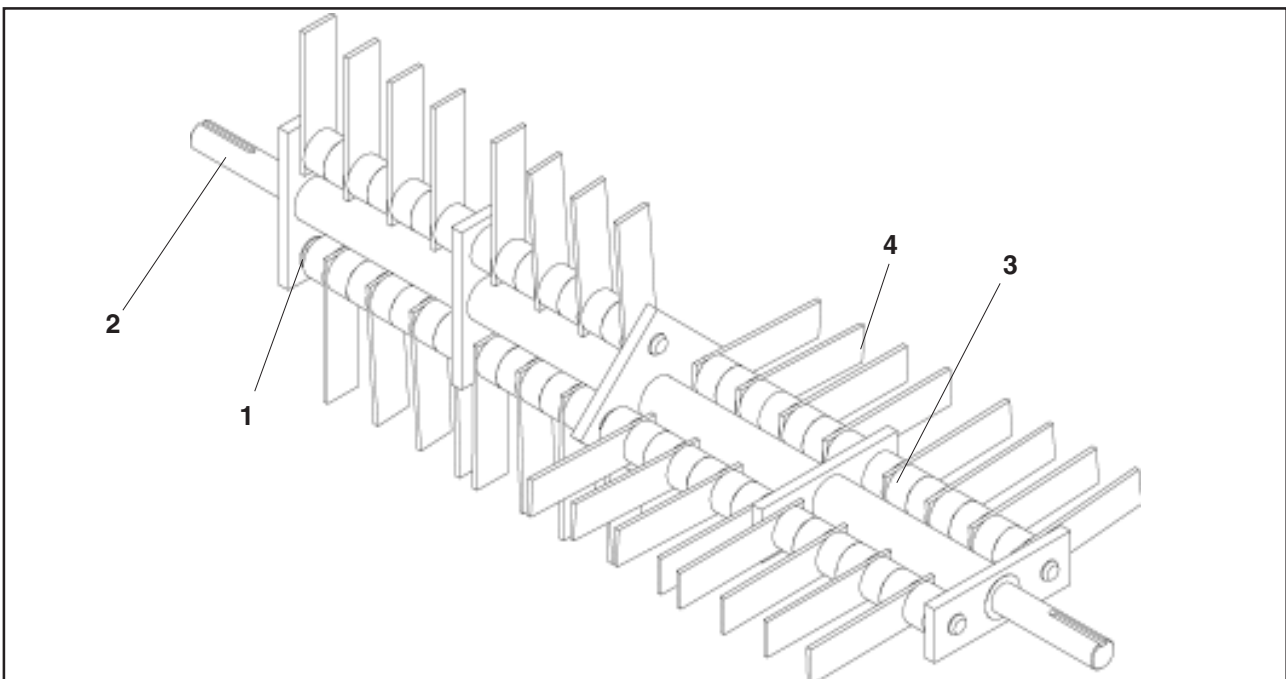

## MAINTENANCE

### Wear/Replacing delta blades

Over time and due to wear, the blades will diminish in length. Once the blades have worn down by about 19 mm (3/4"), the overall length of the blade at the longest point of the blade will be about 64 mm (2 1/2"), and it will be necessary to replace the blades.

It is possible to replace delta blades without removing the rotor shaft. Remove the delta blade by removing the two screws with nuts holding the blade in place.

Turn the new blade until it is properly aligned; see illustration.

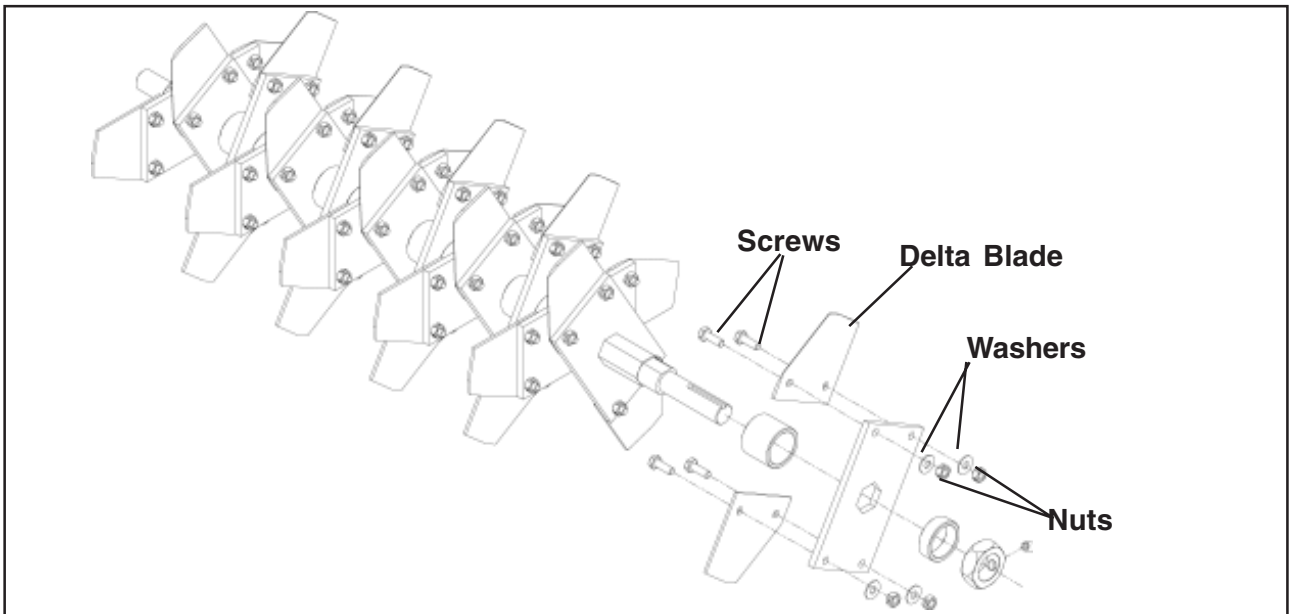

### Wear/Replacing spring tines

Over time and due to wear, the tines will diminish in length. When the tines can no longer be adjusted to comb 6 mm (1/4") into the soil, the tines must be replaced.

the rotor shaft by using a 1/2" socket wrench. Remove the screw and replace the spring tine using the wrench. Fit the new spring tine before removing the tine on the opposite side.

Spring tines can be replaced without removing

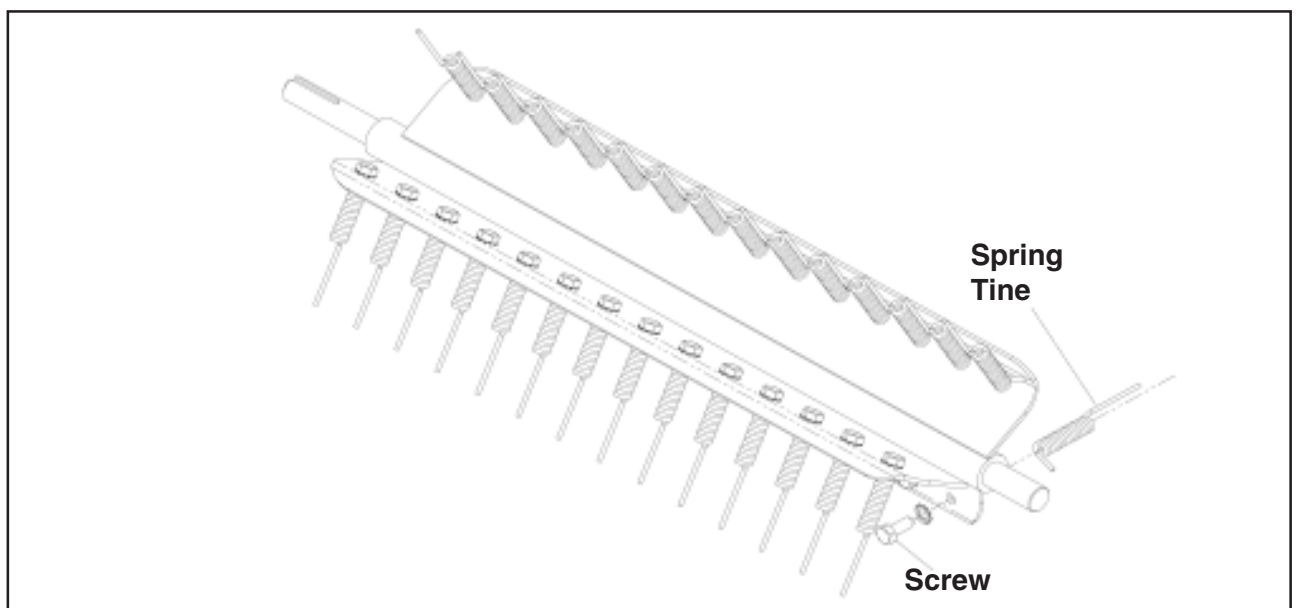

---

# MAINTENANCE

---

## Two minute rule

The machine may be tipped forward to facilitate access for cleaning or service, but **no longer than 2 minutes**.

If the machine is held in this position for too long, the engine can be damaged by gasoline draining into the crankcase. Should this happen, perform an extra oil change on the engine. Remove the spark plug and turn the engine over a few revolutions with the starter handle before starting the engine again.

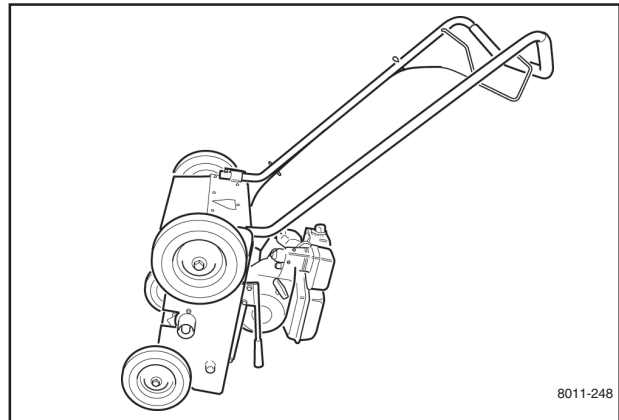

## Cleaning and washing

Regular cleaning and washing will increase the machine's lifespan. Make it a habit to clean the machine directly after use, before the dirt sticks.

Check before rinsing that the fuel tank lid is properly in place to avoid getting water in the tank.

Use caution when using high-pressure spray because warning decals, instruction signs and the engine can be damaged. **Do not exceed 70 bar/1000 PSI water pressure when cleaning.**

Lubricate the machine after cleaning. This is particularly important if the machine is to be stored.



# LUBRICATION

## Lubrication schedule

12/12	1/12	1/52	1/365	DT22		25h	50h	100h	300h	
			👁️	1				⚠️		
(⚠️)	👁️			2		2	👁️		⚠️	
		🔧		3						
		🔧		4						
		🛢️		5						
		🛢️		6						

8011-281

### General

Stop the engine and remove the ignition cable before attempting to lubricate the machine.

Unless otherwise specified, when lubricating with grease use Husqvarna's Universal Grease no. 5310038-01 or Husqvarna's Lubrication Grease UL 21 no. 5310060-74.

Wipe away excessive grease after lubrication.

It is important to avoid getting lubricant on the belt or the drive surfaces on the belt pulleys. Should this happen, attempt to clean them with spirits. If the belt continues to slip after cleaning, it must be replaced.

# LUBRICATION

## 1. Engine oil

The engine should be warm (but not hot) when changing the oil. Warm oil flows out faster and leaves a smaller quantity of old oil inside the engine.

1. Place a suitable vessel underneath the oil drainage screw. Remove the oil dipstick (1) and the oil drainage screw (4).

Tip: Make a channel using a piece of cardboard to lead the oil directly into the vessel and avoid soiling the machine chassis.

2. Allow the engine oil to drain into the vessel; then replace the drainage screw. Tighten it moderately.

### IMPORTANT INFORMATION

**Used engine oil is a health hazard and legislation prohibits disposal on the ground or in nature; it should always be disposed of at a workshop or appropriate disposal location. Avoid skin contact; wash with soap and water in case of spills.**

3. Make sure the machine is parked on even ground. Fill the new oil using the appropriate viscosity according to the diagram, API Service SF-SG, to the upper level mark on the dipstick = threads on the oil dipstick. The engine takes 0.6 liters/0.63 US qt of oil. When checking the oil level, the dipstick should **not** be screwed in.
4. Check that the rubber gasket is in position and screw the dipstick back into place. Do not tighten it askew or too hard or you may damage the threads.
5. Wipe up any spilled oil.

### Checking the engine's oil level.

Make sure that the machine is parked on even ground with the engine stopped when checking the oil level.

1. Unscrew the dipstick and wipe it using paper towel or a lint-free rag.
2. Replace the dipstick without screwing it in. Remove and check the level on the dipstick.
3. Fill oil as necessary to the lip of the dipstick hole. Oil type, see above.

4. Check that the rubber gasket is in position and screw the dipstick back into place. Do not tighten it askew or too hard or you may damage the threads.



### WARNING!

**Engine oil can be very hot if it is drained directly after stopping the machine. Allow the engine to cool somewhat.**

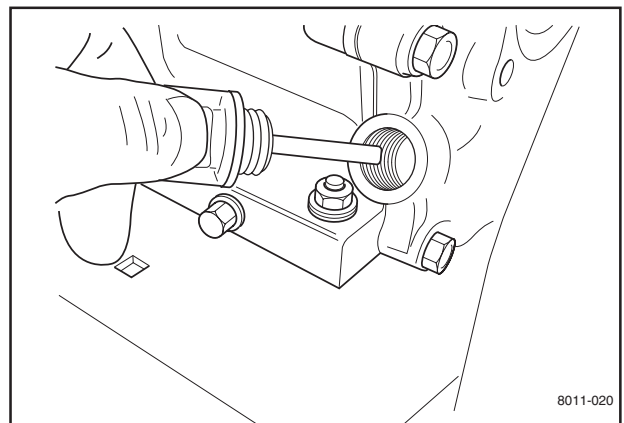
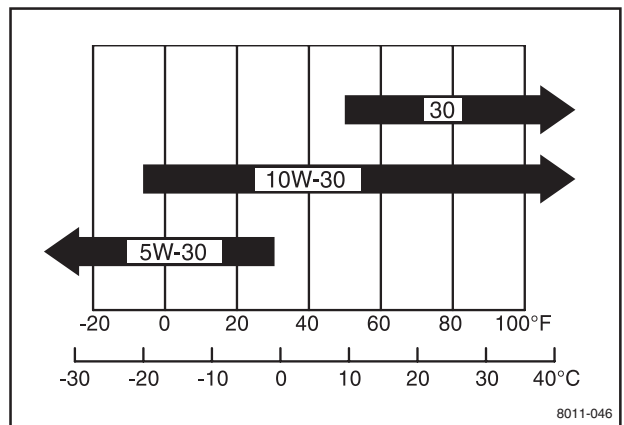
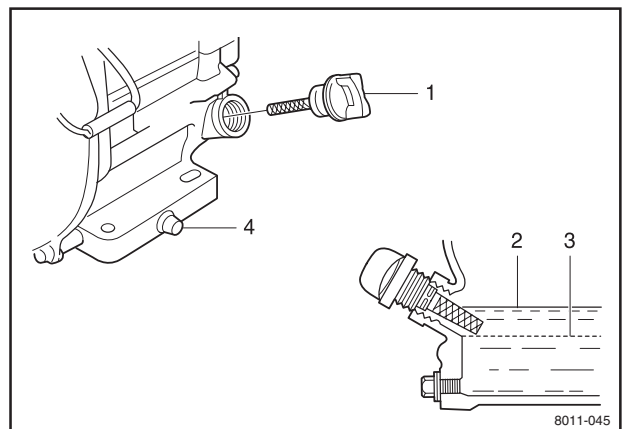

# LUBRICATION

## 2. Depth knob with depth lock

Lubricate the threads regularly with grease to avoid binding or locking. It is particularly important to lubricate the threads after cleaning.

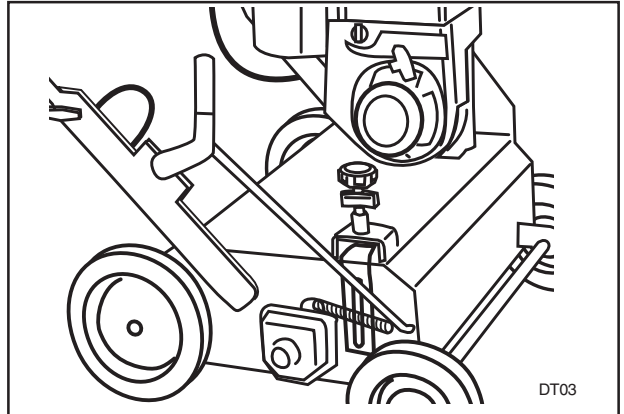

## 3. Blades

Cover the blades with a thin coat of oil to avoid rust. This is particularly important prior to winter storage or if the machine will not be used for a period of longer than 30 days.

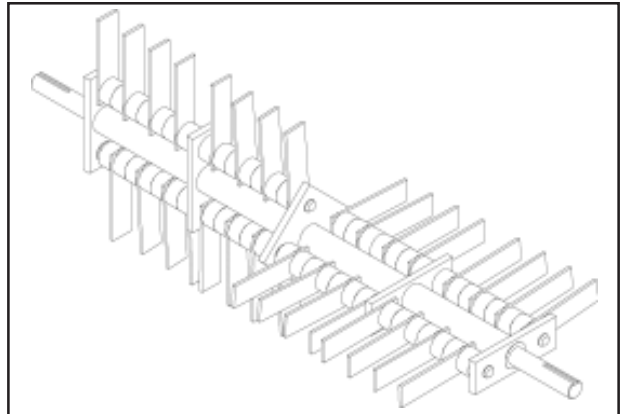

## 4. Depth lever

It is important to lubricate all links and joints so that they do not bind. Use 30W engine oil.

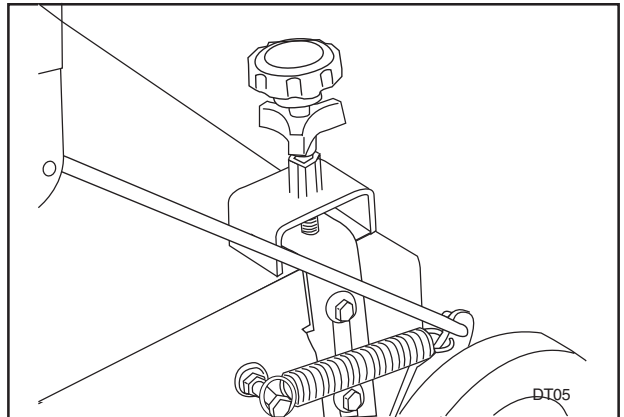

## 5. Handle

Lubricate the joints at both sides of the handle with an oil can.

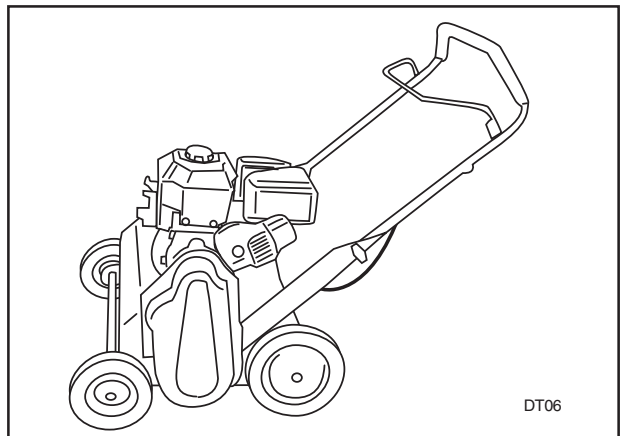

# TROUBLESHOOTING

Symptom	Cause	Action	
<b><u>The engine will not start</u></b>			
• User error	Fuel valve closed.	Open the fuel valve.	
	Choke valve open. engine.	Close the choke with cold	
	Engine switch in OFF position.	Turn the engine switch to ON.	
• Fuel system	Fuel tank empty.	Fill with fuel.	
	Machine stored without observing proper procedure from chapter "Storage/Winter storage"	Clean tank, sludge reservoir and empty carburetor. Fill the tank with fresh fuel.	
	Contamination, water or ice in fuel system.	Clean tank, sludge reservoir, fuel lines and carburetor. Fill the tank with fresh fuel.	
• Spark plug	Carburetor problems.	Contact an authorized service workshop.	
	Wrong spark plug type.	Replace the spark plug.	
Short circuit.	Build-up on electrodes. replace spark plug.	Check electrode gap and clean or	
	Gasoline or oil on the spark plug.	Clean the spark plug. Air the engine out. Start with full throttle.	
• No spark after checking spark plug	Faulty engine switch, cable or ignition.	Contact an authorized service workshop.	
• Low compression	Serious interior engine damage or faulty valves.	Contact an authorized service workshop.	
<b><u>Engine is under powered or runs unevenly</u></b>			
• Air filter	Clogged air filter.	Clean or replace the air filter.	
• Fuel system	Machine stored without observing proper procedure from chapter "Storage/Winter storage"	Clean tank, sludge reservoir and empty carburetor. Fill the tank with fresh fuel.	
	(Blue exhaust)	Tank filled with 2-cycle mixed oil.	Fill the tank with proper fuel.
	(Voluminous blue-white exhaust)	Tank filled with diesel.	Clean tank, sludge reservoir and empty carburetor. Fill the tank with proper fuel.
(Black exhaust)	Choke left on.	Open choke valve.	
	Clogged air filter.	Clean or replace the air filter.	
	Carburetor problems.	Contact an authorized service workshop.	
• Ignition system	Wrong spark plug type.	Replace the spark plug.	
	Build-up on electrodes. replace spark plug.	Check electrode gap and clean or	
Short circuit.	Faulty ignition unit.	Contact an authorized service workshop.	
• Low compression (possible blue exhaust)	Serious interior engine damage or faulty valve. exhaust)	Contact an authorized service workshop.	

# STORAGE

## Winter storage

At the end of the season, the machine should be readied for storage (or if it will not be in use for longer than 30 days). Fuel allowed to stand for long periods of time (30 days or more) can leave sticky residues that can plug the carburetor and disrupt engine function.

Fuel stabilizers are an acceptable option to reducing sticky residues during storage. If alkylate gasoline (Aspen) is used, stabilizers are unnecessary because this fuel is stable. However, you should avoid switching between regular and alkylate gasoline as sensitive rubber components can harden. Add stabilizer to the fuel in the tank or in the storage container. Always use the mixing ratios specified by the manufacturer of the stabilizer. Run the engine for at least 10 minutes after adding the stabilizer so that it reaches the carburetor. Do not empty the fuel tank and the carburetor if you have added stabilizer.



### WARNING!

Never store an engine with fuel in the tank indoors or in poorly ventilated spaces where fuel vapor can come in contact with open flame, sparks or a pilot light such as in a boiler, hot water tank, clothing drier, etc.

Handle the fuel with caution. It is very flammable and careless use can cause serious damage to person and property. Drain the fuel into an approved container outdoors and far away from open flame. Never use gasoline for cleaning. Use a degreaser and warm water instead.

## Service

When ordering spare parts, please specify the purchase year, model, type, and serial number.

Always use genuine Husqvarna spare parts.

An annual check-up at an authorized service workshop is a good way to ensure that your machine performs its best the following season.

To ready the machine for storage, follow these steps:

1. Clean the machine carefully, particularly the chassis and working equipment. Mend damage to the paint to prevent rust.
2. Inspect the machine for worn or damaged parts and tighten any nuts or bolts that may have become loose.
3. Change the engine oil; dispose of properly.
4. Open the fuel valve. Empty the fuel tank (1) and the carburetor (2).

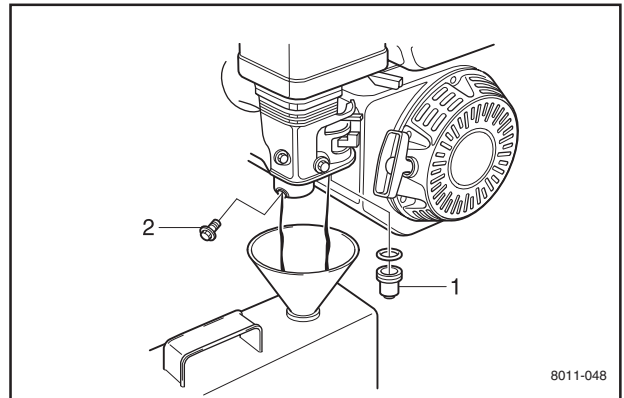

5. Close the fuel valve.
6. Remove the spark plug and pour about a tablespoon of engine oil in the cylinder. Turn over the engine so that the oil is evenly distributed and then refit the spark plug. Put the engine in the compression phase where the triangle mark on the sleeve of the starter is aligned with the upper hole in the starter. Note: Compression phase occurs every second revolution.

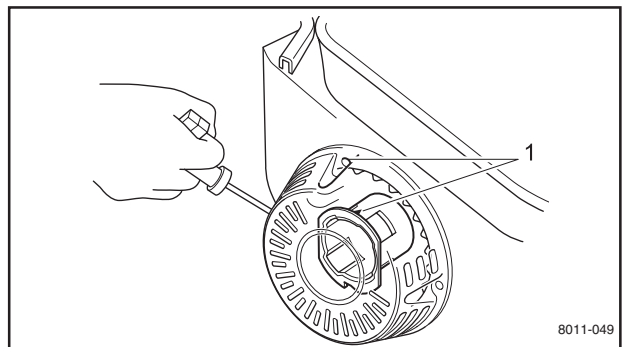

7. Lubricate all grease nipples, joints and shafts as described in the chapter "Lubrication/ Lubrication schedule".
8. Store the machine in a clean, dry place and cover it for extra protection.

---

## TECHNICAL DATA

---

<b>Specifications</b>	<b>DT22</b>
Engine	Honda GX160
Cylinder volume	163 cm <sup>3</sup> (9.9 cu in)
Power	5.5 hp (4 kW) at 3600 RPM
Torque	10.8 Nm at 2500 RPM
Spark plug	NGK BPR6ES DENSO W20EPR-U
Fuel volume	3.6 liters/0.95 US Gal
Primary drive	One V-belt
Dethatching breadth	55.8 cm (22")
Clutch control	Handle-mounted with automatic safety declutching
Clutch mechanism	Belt tightener with spring return and idling pulley
Seeding breadth	55.8 cm (22")
Depth setting	Adjustable depth control with lever mechanism with lock and stop
Flail blade reel	52 case-hardened steel blades with 1.6 cm (5/8") spacers 0.3 x 2.5 x 8.9 cm (1/8" x 1" x 3 1/2")
Delta blade reel	20 austempered 12-gauge steel blades with 5 cm (2") spacers
Spring tine reel	Not applicable
Handle	Fixed, ergonomic design with upholstery
Catcher bag	0.23 m <sup>3</sup> (8 ft <sup>3</sup> ) synthetic material on frame with wheels
Seed hopper	22.3 l (1.358 inch <sup>3</sup> ) or approx. 13.6 kg (30 lbs) seed. Self-propelled stirring. Inspection window.
Weight	Dethatcher 65.3 kg (144 lbs) with seed hopper 74.8 kg (165 lbs) with catcher bag 71.2 kg (157 lbs)
Width	71 cm (28")
Length	68 cm (26 3/4") without handle 127 cm (50") with handle
Height	61 cm (24") without handle 102 cm (40") with handle
Distance between axles	45 cm (17 3/4") center to center
Bearings	3/4" closed flanged cartridge
Wheels	Front 8" x 1 3/4" Back 10" x 2 3/4" catcher bag Back 10" x 1 3/4" seed hopper

---

# ASSEMBLY INSTRUCTIONS

---

## Assembly – delivery service

1. Rotate the handle and tighten it in place.
2. Fill the engine with the manufacturer-recommended oil. See section "Lubrication/Engine oil".
3. Test the clutch. Make sure that the clutch expansion spring disengages easily.
4. The engine RPM is preset by the manufacturer. Idle speed is 1250–1400 RPM. Maximum engine speed is 3600 RPM.

See the engine manual for instructions on adjusting the regulator and carburetor if the engine speed is not within these limits.

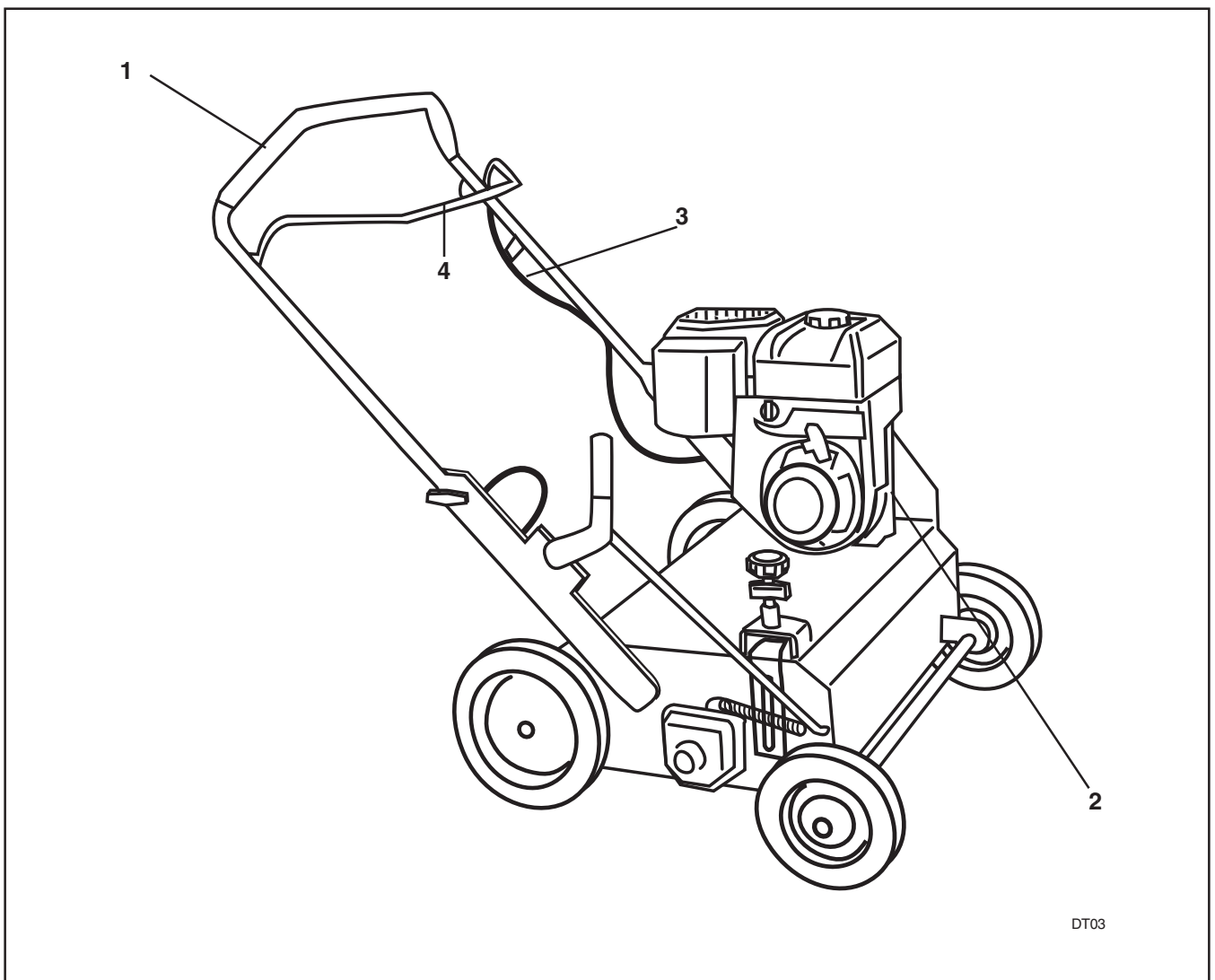

1. Handle
2. Oil refill engine
3. Clutch cable
4. Clutch bail

# BAGGER ASSEMBLY

## Assembly directions, catcher bag

(Part No. 539106667)



### WARNING!

**DO NOT use or start the engine until the catcher bag is in place.**



### WARNING!

**Machines equipped with a catcher MUST not be used with defective catcher bags or without the catcher bag. They pose a risk of thrown stones, eye injury and inhalation of pollution.**



### WARNING!

**DO NOT attempt to unblock bagger chute while engine is running. Stop engine before removing grass and debris.**

1. Remove rear cover, it is not used with the bagger attachment.
2. Disconnect cable on handle, remove clutch bail from handle.
3. Remove handle from unit saving hardware.
4. Place a stable support under the rear frame to support the unit when the rear wheels are removed.
5. Remove the two (2) retaining rings on the rear wheel (they are not reusable, new rings are provided in the kit). Remove wheel from rear axle. (Some units have cotter pins instead of retaining rings.)
6. Loosen one (1) set screw on the locking collar. Using a punch loosen the locking collar on the rear axle. Repeat on the other side of unit.

7. Remove rear axle from unit. The wheel that is pinned to the axle can remain on the axle.

**NOTE:** If axle is rusty, remove rust with fine sandpaper.

**NOTE:** Rubber flapper does not have to be removed.

8. Remove bearings from the frame, retain hardware.
9. Install tray matching screw holes in main frame. See Figure 1.

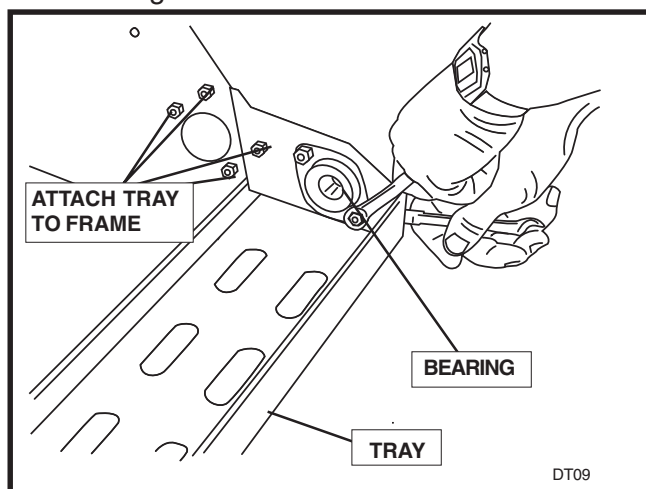

**FIGURE 1**

10. Apply bearings on the inside of the tray, DO NOT tighten hardware, just snug it. See Figure 1.

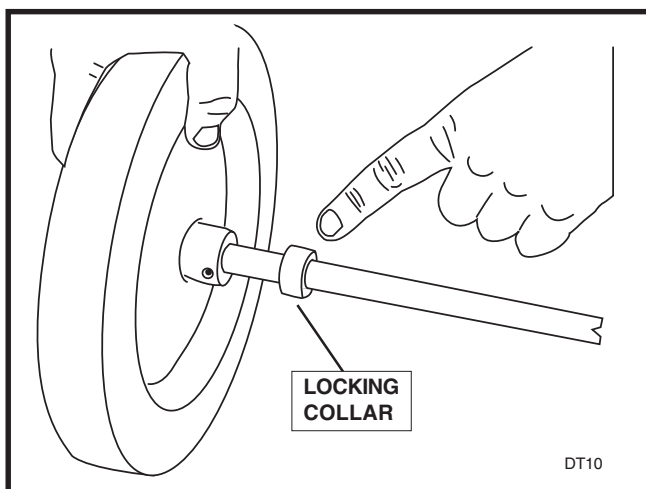

**FIGURE 2**

11. Add locking collar to shaft, install shaft through bearings and tray. Place the other locking collar on the shaft. See Figure 2. Using a punch tighten the locking collars, then tighten the set screw. Repeat for the other side.

---

# BAGGER ASSEMBLY

---

- Slide wheel on and apply two (2) retaining rings. (Some units use a cotter pin instead.)

**NOTE:** The teeth on the retaining rings should point away from the wheel.

- Tighten wheel bearing hardware on both sides.

**NOTE:** If you have not installed the flail reel shaft, do so now.

- Install rubber flaps between flail blades on the rake shaft. See Figure 3. If this shaft is installed, you **DO NOT** have to remove the shaft from the unit to install the the rubber flaps.

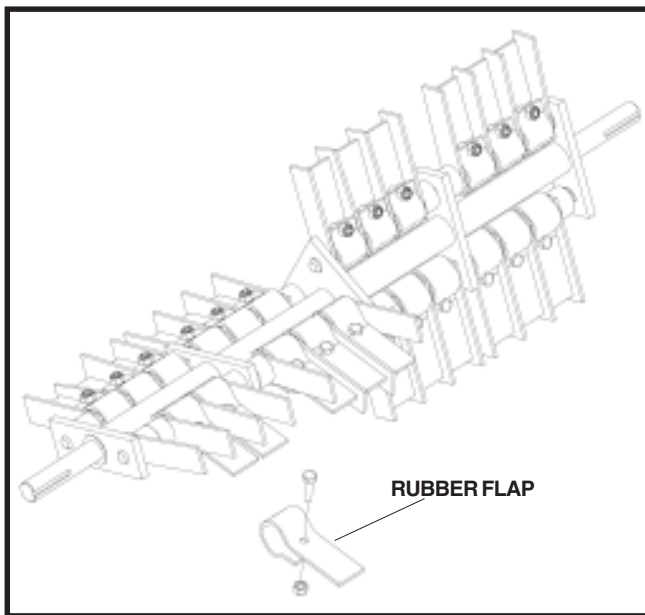

**FIGURE 3**

- Remove belt guard. Remove cable by removing the pulley. See Figure 4. Attach new cable and replace pulley. Save the old cable for use when the bagger is not used.

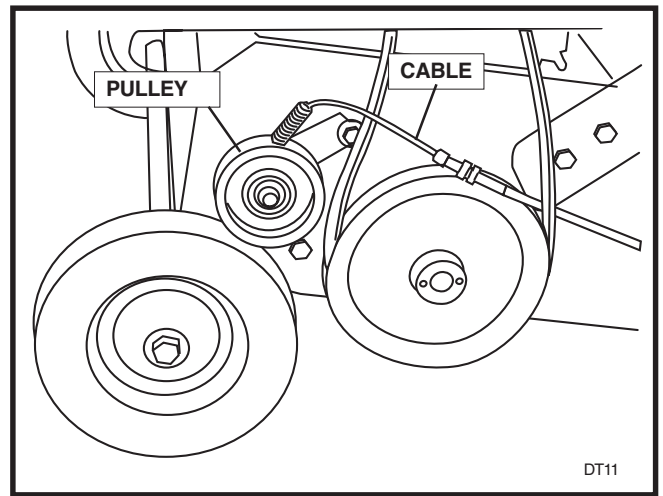

**FIGURE 4**

- Attach the chute to the mainframe.

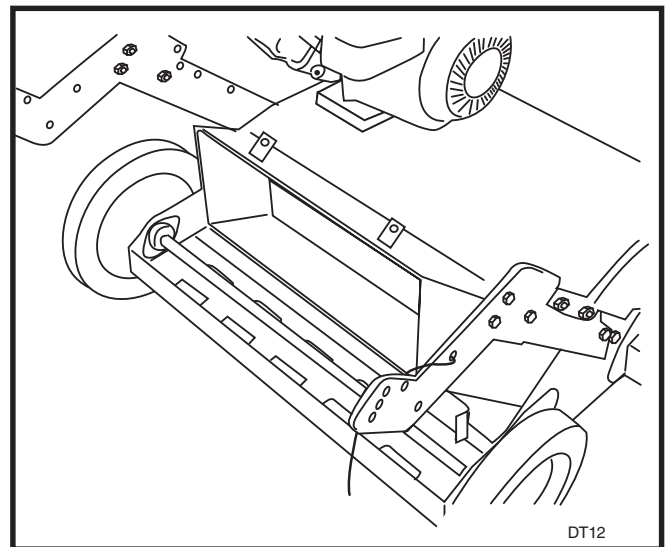

**FIGURE 5**

- Install two extenders on the outside of the lower handle assembly. Attach the lanyards with pins to the extenders as shown in Figure 6.

# BAGGER ASSEMBLY

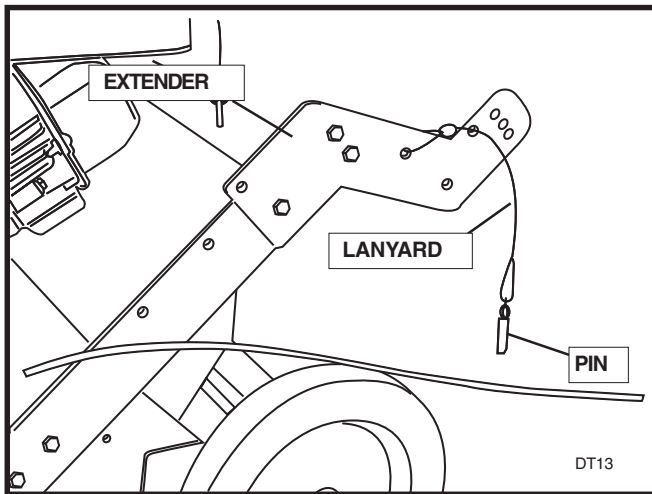

FIGURE 6

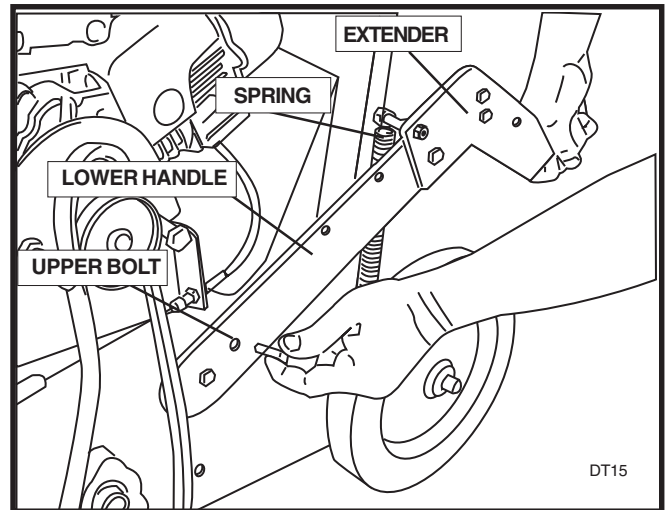

FIGURE 8

18. Place door in position and set the hinge bolts. DO NOT tighten the bolts, leave at least 1/16" space. Thread nut on to the bolt. See Figure

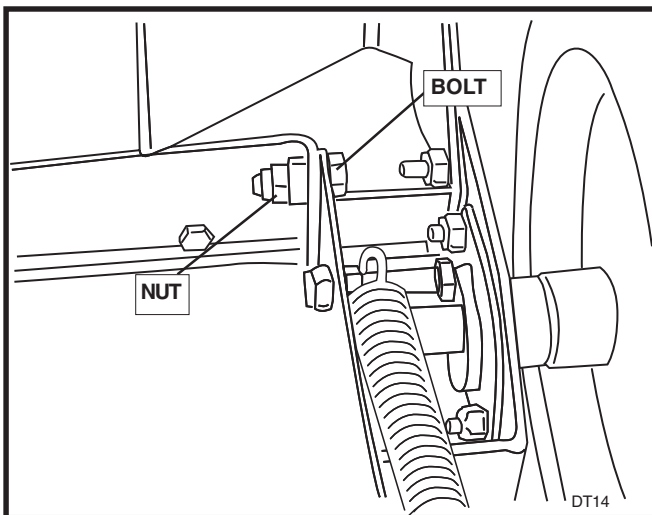

FIGURE 7

20. Attach upper handle to the extenders.

21. Attach upper end of cable to the handle and install cable through clutch bail. Fit clutch bail into the handle. See Figure 9.

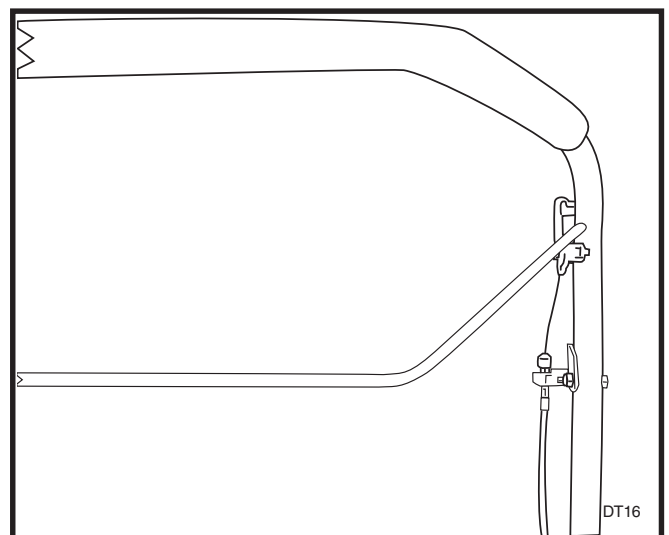

FIGURE 9

19. Remove upper bolt from lower handle and rotate handle toward the ground. Using the hardware provided install the spring to the extender. Rotate handle back to original position stretching spring, re-install the 3/8" bolt into the lower handle. Repeat on other side. See Figure 8.

# BAGGER ASSEMBLY

22. Wire tie the cable to the handle. See Figure 10.

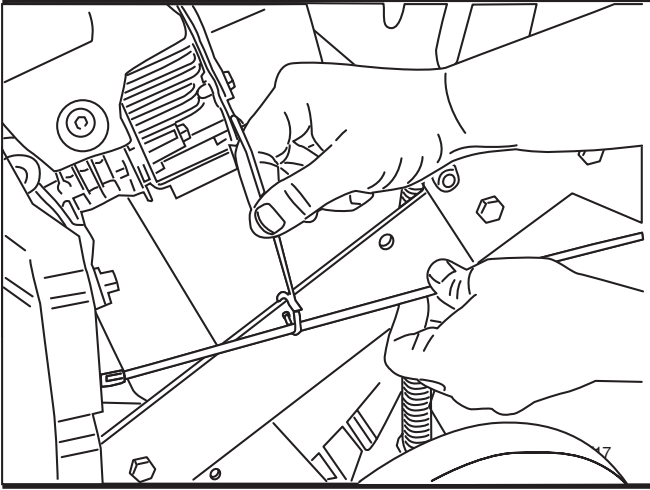

FIGURE 10

23. Check adjustment of clutch cable. If cable needs adjusting, the adjusting should be done at the lower end with the spring.

Adjust as follows:

Pull the clutch bail tightly against the handle.

The spring stretch should be 3/8" - 1/2".

If this range is not met, the adjustment should be done closest to the spring.

24. Replace belt cover.



## WARNING!

DO NOT use or start the engine until the catcher bag is in place.



## WARNING!

Machines equipped with a catcher **MUST** not be used with defective catcher bags or without the catcher bag in place. They pose a risk of thrown stones, eye injury and inhalation of dust.

25. Fit catcher bag to the bag frame as follows:

- Affix the bag's plastic rails to the frame.
- Install the upper portion of the bag between the two struts on the upper portion of the frame and affix the bag to the front edge of the frame.
- Press on the snaps, one on each side. See Figure 11.

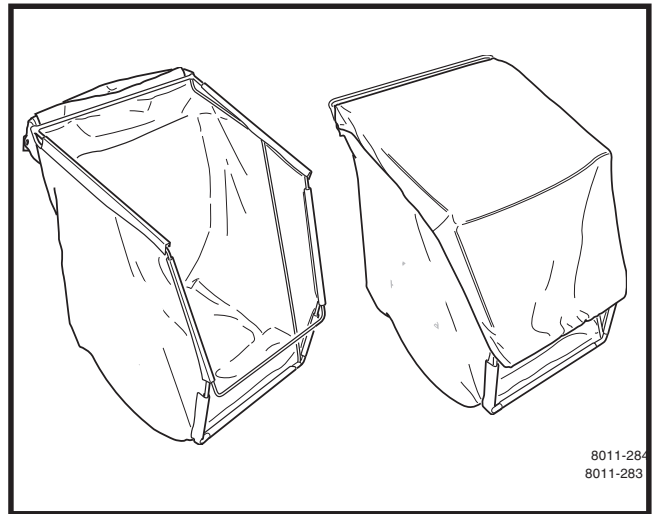

FIGURE 11

26. Attach bag to unit.

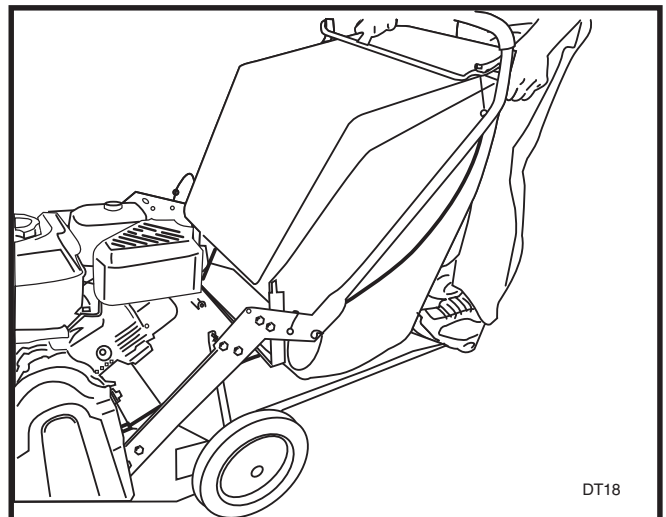

FIGURE 12

# BAGGER ASSEMBLY

## Instructions for the catcher bag



### WARNING!

Machines equipped with a catcher **MUST** not be used with defective catcher bags or without the catcher bag.

They pose a risk of thrown stones, eye injury and inhalation of pollution.

### Catcher bag

Insert the catcher bag into the underside of the handle and open the safety door place bag on the catcher chute.

See "Assembly instructions\Assembly directions, collector bag".

### Correct height setting

The thatch collected will be thrown into the catcher by the force arising from the flail blades combing through the grass. The blades may not strike the soil. If the blades come in contact with the soil, they will claw, which results in ineffective dethatching.

### Collection conditions

One achieves best results if the lawn is short and dry. Wet lawns make collection less effective. If the grass is long, one may end up pulling and tearing at the lawn. If the layer of thatch is thick, Husqvarna recommends going over the lawn first in one direction and then again in a perpendicular direction. A thick layer of thatch may have formed over several years, and the lawn may need combing 2-3 times before it is removed completely. Do not attempt to remedy a major problem by combing the lawn just once.

### Maintenance

Check prior to use that the catcher is properly assembled and that the bag is not damaged. See "Assembly instructions\Assembly directions, collector bag".

Clean the equipment after use.

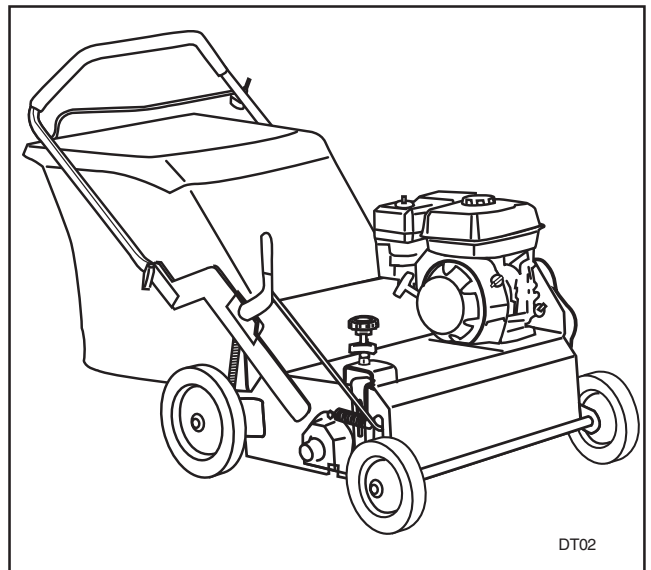

FIGURE 13

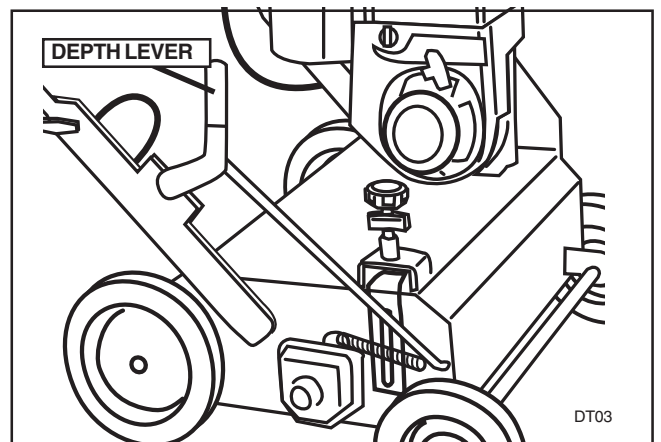

FIGURE 14

# SEEDER ASSEMBLY



## WARNING!

**DO NOT use or start the engine until the seeder is in place.**

1. Remove rear cover, it is not used with the seeder attachment.
2. Place a stable support under the rear frame to support the unit when the rear wheels are removed.
3. Remove the two (2) retaining rings on the rear wheel (they are not reusable, new rings are provided in the kit). Remove wheel from rear axle. (Some units use a cotter pin instead of retaining rings.)
4. Loosen one (1) set screw on the locking collar. Using a punch loosen the locking collar on the rear axle. Repeat on the on the other side of the unit.
5. Remove bolts holding the bearings to the frame.
6. Remove rear axle from unit. The wheel that is pinned to the axle can remain on the axle.
7. Remove push nut (push nut is not reusable, a new one is provided in the kit) from the right side of the rubber flap rod. Lay the rubber flap away from the right side so the cable can run between the flap and frame. (Some units use cotter pins to hold the flap rod.)
8. Route the cable from the seed gate between the bottom of the frame and the top of the rubber flap. See Figure 1.

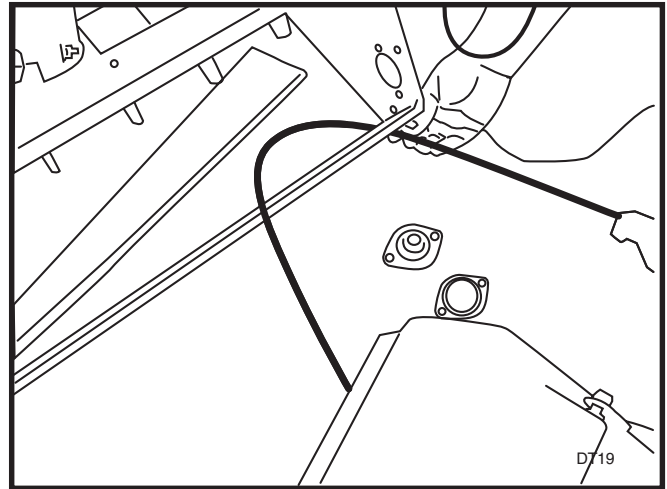

**FIGURE 1**

9. Place seed box on unit, replace bearing with eccentric collar to the outside. The screws that attach the seedbox to the frame **MUST** have washers inside the seedbox on the screws. **DO NOT** overtighten and deform the plastic, snug-up **ONLY**. See Figure 2.

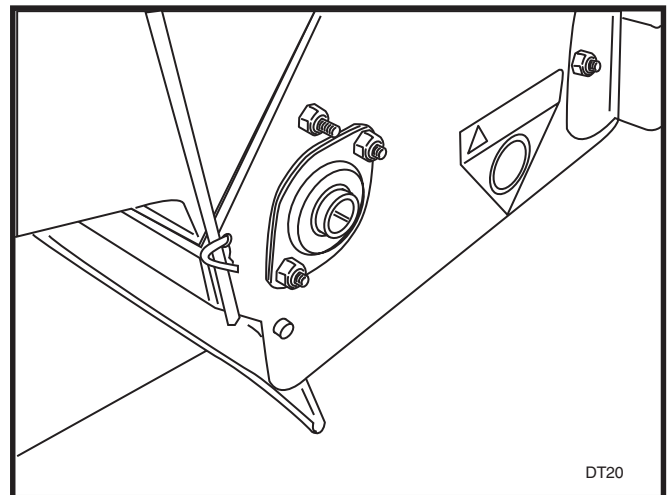
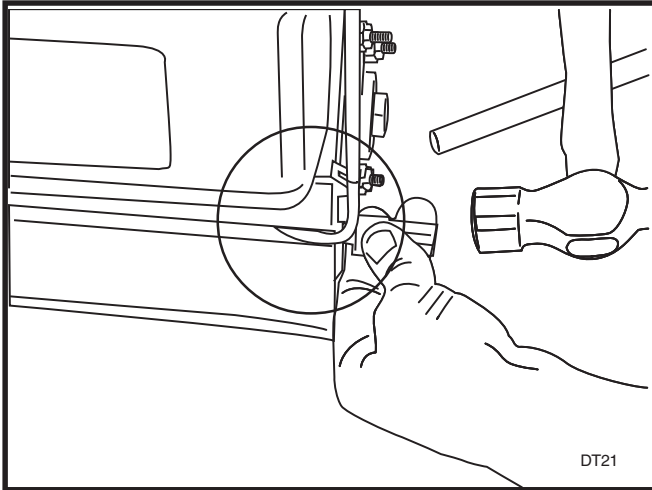

**FIGURE 2**

**NOTE:** Do not tighten hardware on the bearings until the axle is installed.

# SEEDER ASSEMBLY

10. Re-attach rubber flap rod with push nut to the frame being sure cable is routed above flap rod. See Figure 3. (Some units use cotter pins).



**FIGURE 3**

11. Using two (2) wire ties attach cable to the frame. See Figure 4.

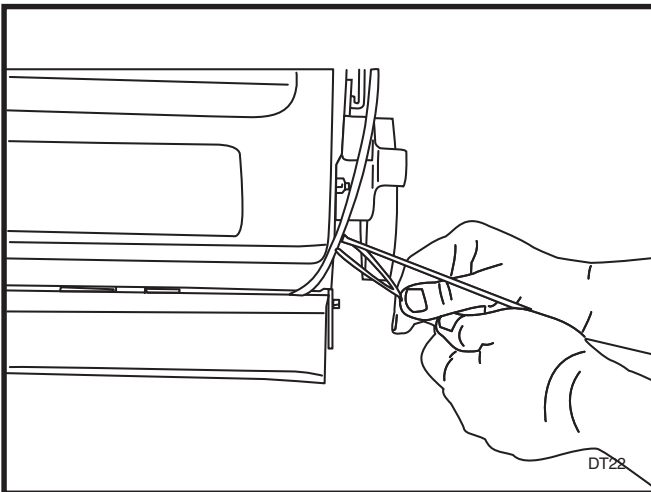

**FIGURE 4**

12. Place agitators in the seed box with screw holes toward the center.
13. Make sure locking collar is on the axle then thread the axle through the side of the box and through the agitators in seed box.
14. Rotate axle to line up the holes with the agitators holes. Using the self-tapping screws attach the agitators to the rear axle. See Figure 5.

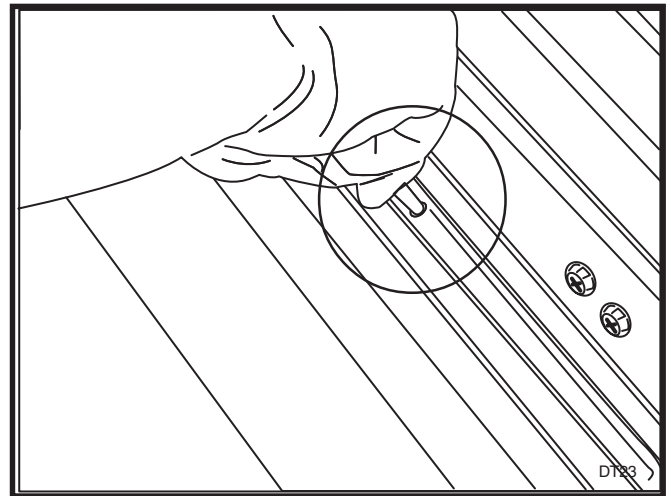

**FIGURE 5**

15. Center agitators in seed box and tighten bearing locking collars. Use punch to tighten the collar then tighten the set screw. Repeat for the other side.

16. Slide wheel on and apply two (2) retaining rings. (Some units use cotter pins instead of retaining rings.)

**NOTE:** The teeth on the retaining rings should point away from the wheel.

17. Tighten the bearing bolts.

18. Attach the control cable to the inside of the upper handle in the holes provided.

19. Apply ON/OFF decal to the handle. See Figure 6.

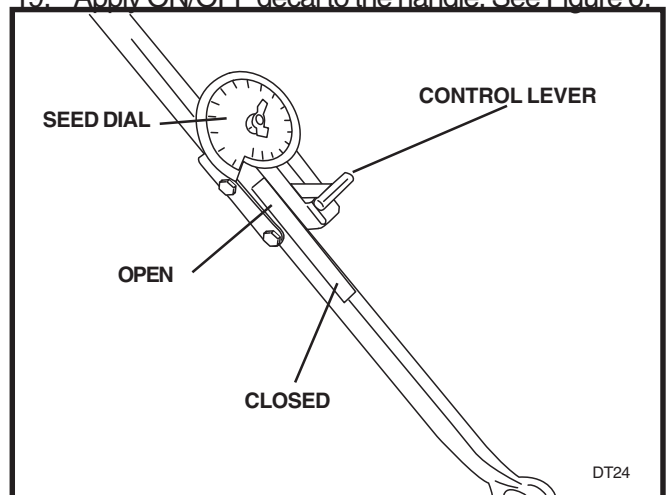

**FIGURE 6**

---

## SEEDER ASSEMBLY

---

20. Attach the cable with a wire tie farther up the handle.
21. Check adjustment of the cable by tipping unit forward confirming that when the control lever is in the closed position the seedgate is fully closed.

If the seedgate needs adjusting, loosen the screw and nut holding the cable clamp. Move the cable back or forward in the clamp until the seedgate is fully closed when the control lever is in the closed position. **DO NOT** move the seedgate with your hand, use the cable to move the seedgate for a more accurate adjustment.

22. To check the seed dial adjustment, insert a 1/8" drill bit into one of the holes in the seed gate, the seed dial should read 3 1/2. If not, adjust the cable by loosening the screw and nut holding the cable clamp. Move the cable back or forward in the clamp until the seed dial reads 3 1/2.

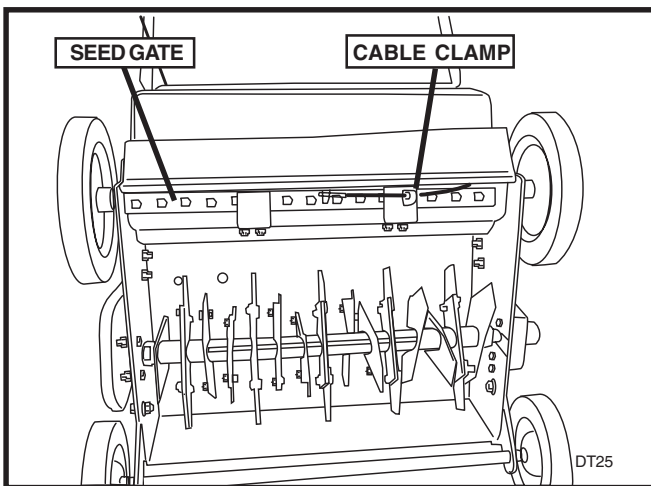

**FIGURE 7**

23. Make sure the cable moves freely. **NEVER** kink the cable.
24. Re-check the unit to see if it functions properly.

# SEEDER ASSEMBLY

## Instructions for the seeder

### IMPORTANT INFORMATION

The equipment is only intended to sow grass seeds on lawns. All other use such as spreading lime or manure is incorrect and could damage the equipment.

### General information

The seed hopper is mounted on the rear of the machine. The seeds are released with a lateral space of approximately 3.8 cm ( 1 1/2") after the blades have cut the soil.

Delta blades are recommended for seeding.

For more uniform coverage, we recommend first sowing in one direction and then sowing at approximately 45° from the first sowing pass. With this method, the seed flow should be set at half of the recommended quantity for approximately 93 m<sup>2</sup> (1000 ft<sup>2</sup>).

The seeder does not remove the thatch layer. The thatch should be removed before beginning the seeding process. The seeds must be covered with soil to germinate.

### Adjusting the seed hopper

A seed application chart is located on the back of the seed hopper. The seed dial is also located on the handle bar of the unit. Set the seed flow by loosening the wing nut, rotating the dial to the correct setting and tightening the wing nut. The seed control lever is located on the handle of the seeder.

When the seed control lever is in the open position, the dial controls the degree that the seed gate will be opened. The flow of seed can be stopped with the seed control lever when turning and refilling seeds.

### Maintenance

Make sure before use that the release holes for the seeds are not plugged with soil or similar.

Clean the equipment carefully after use.

Lubricate after cleaning to prevent corrosion. Lubricate joints and bearings and unpainted metal surfaces.

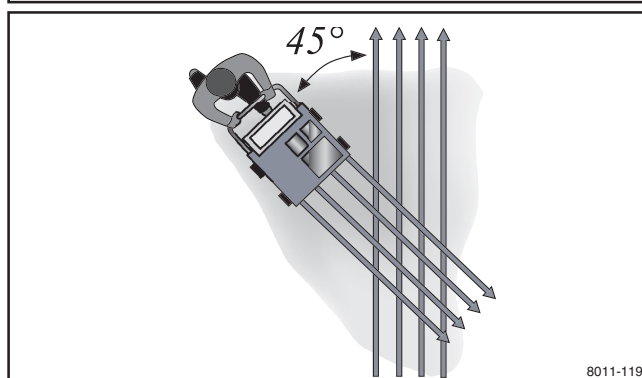
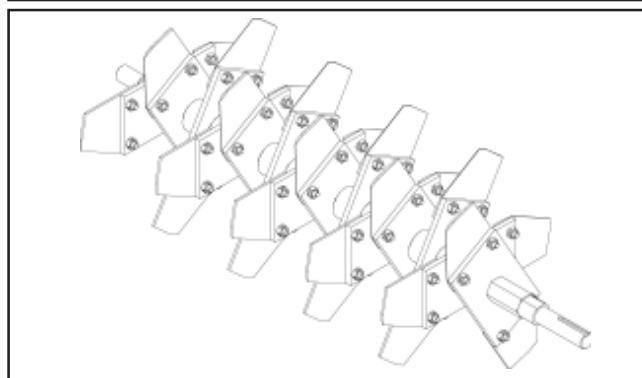
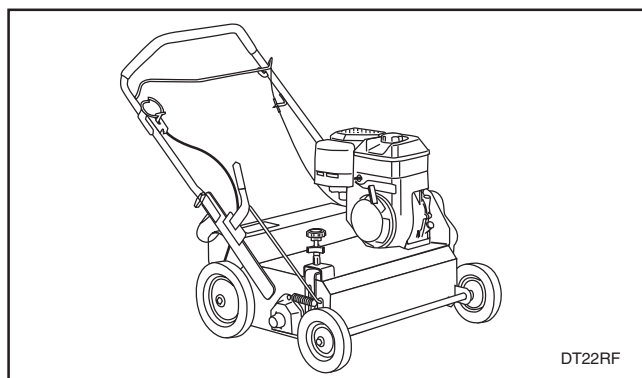

### WARNING!

Be careful of the muffler when opening the seed hopper lid as it can be very hot and cause burns.



## Sound - Model 968999132

**LWA**

**102**

### Sound Test

Sound test conducted was in accordance with 2000/14/EC and was performed on 07 October 2002 under the conditions listed.

General Condition: Clear

Temperature: 66 ° F.

Wind Speed: Less than 8 mph

Test Report: R092502-01

## Vibration - Model 968999132

**11.5**  
**rms**

### Vibraton Level

Vibration level at the operators handles were measured in the vertical, lateral, and longitudinal directions using calibrated vibration test equipment.

Tests were performed on 07 October 2002 under the conditions listed:

General Condition: Clear

Temperature: 66 ° F.

Wind Speed: Less than 8 mph

Test Report: R092502-01









114 01 94-26



2003W10