

Operator's Manual **Auto Mower**

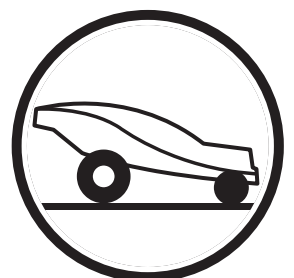

Please read the Operator's Manual carefully and make sure you understand the instructions before using the machine

English

Operator's Manual for Auto Mower

Contents

| | | | |
|--|-----------|---|-----------|
| Introduction | 4 | Menu functions | 29 |
| Congratulations | 4 | Main menu | 29 |
| Symbols | 5 | 1. Commands | 30 |
| Symbols on Auto Mower | 5 | 2. Timer | 30 |
| Symbols in the Operator's Manual | 6 | 3. Installation | 32 |
| Safety instructions | 7 | 4. Settings | 35 |
| Use | 7 | Use | 40 |
| Transport..... | 8 | Charging a discharged battery | 40 |
| Maintenance | 8 | Starting the Auto Mower | 40 |
| Presentation | 9 | Using the timer | 41 |
| Function Auto Mower | 10 | Stopping the Auto Mower | 41 |
| Capacity | 12 | Restart | 41 |
| Installation | 13 | Turning off the Auto Mower | 41 |
| A. Preparations | 13 | Adjusting the cutting height | 42 |
| Auto Mower, what is what? | 14 | Maintenance | 43 |
| B. Planning the installation | 15 | Battery | 43 |
| C. Placement of the charging station | 20 | Winter Storage | 43 |
| D. Charging the battery | 22 | Cleaning | 44 |
| E. Laying out the boundary wire | 22 | Replacing the blade units | 45 |
| F. Connecting the boundary wire | 23 | Trouble shooting | 46 |
| G. Checking the installation | 25 | Fault messages | 46 |
| H. Linking the Auto Mower to the charging station..... | 25 | Trouble shooting chart | 48 |
| Control panel | 26 | Technical data | 49 |
| Shortcuts | 27 | EU declaration of conformity | 50 |
| Program | 27 | | |
| Section | 28 | | |
| Numbers | 28 | | |
| Main switch | 28 | | |

Auto Mower Helpdesk

Telephone number: 020 - 77 77 22

Monday - Friday: 8.00 - 20.00

Saturday - Sunday: 12.00 - 16.00

INTRODUCTION

Introduction

Congratulations

Thank you for purchasing a Husqvarna Auto Mower. The Husqvarna Auto Mower is designed to offer user friendliness, high operating safety and a long service life. Auto Mower has been built to mow areas that contain slopes and confined passages as well as many trees and bushes. Using only a minimum of supervision and maintenance you can have a well-kept lawn throughout the season.

This Operator's Manual is a valuable document. By following its contents (use, maintenance, etc) you can contribute towards a long life for the mower and enhance its trade-in value. Read through the Operator's Manual carefully before you start to install and use your Auto Mower.

Save the Operator's Manual and, if you sell your Auto Mower, make sure you hand it over to the new owner.

Husqvarna Auto Mower is designed to mow the grass on ordinary lawns free from stones, large branches and the like. All other types of use are incorrect. The manufacturer's instructions with regard to driving, maintenance, and repair must be followed precisely.



WARNING!

Under no circumstances may the original design of the Auto Mower be modified without the expressed permission of the manufacturer.

Unauthorized modifications and/or components can result in serious disruptions and the risk of personal injuries.

Always use original spare parts.

SYMBOLS

Symbols

Symbols on the Auto Mower

These symbols can be found on the lawn mower. Study them carefully so you understand their significance.

IMPORTANT INFORMATION

Read through the Operator's Manual carefully and understand the content before using the Auto Mower.



1001-003



WARNING

Auto Mower can be dangerous if used incorrectly.

- The warnings and safety instructions in the Operator's Manual must be followed carefully for the mower to be used safely and efficiently.



1001-002

- Keep your hands and feet away from the rotating blades. Never put your hands or feet close to or under the body of the Auto Mower while it is running.



3012-274

- Never use the Auto Mower if people, especially children, or pets are nearby.



3012-273

- This product conforms to the applicable EU Directives.



6001-024

SYMBOLS

Symbols in the Operator's Manual

These symbols can be found in the Operator's Manual. Study them carefully so you understand their significance.

- Inspection and/or maintenance should be carried out with the main switch set to "OFF".



3012-288

- Always wear protective gloves when working with the mower's underframe.



3012-272

- Never use a high-pressure washer or even running water to clean the Auto Mower.

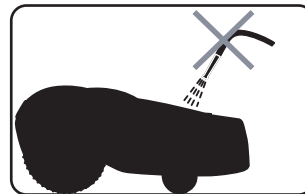

3012-271

- The warning box warns of the risk of **personal injury**, especially if the instructions are not followed.

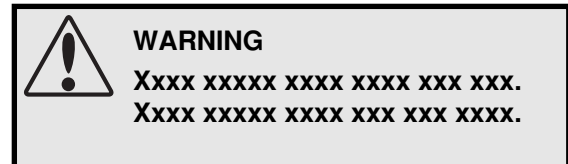

- The information box indicates the risk of **material damage**, especially if the instructions are not followed. The box is also used where there is a risk of user error.

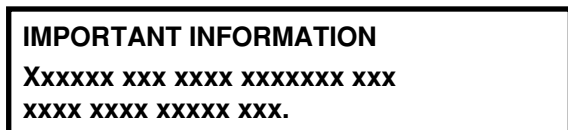

SAFETY INSTRUCTIONS

Safety Instructions

Use

- Read through the Operator's Manual carefully and understand the content before using the Auto Mower.



1001-003

- Check that there are no stones, branches, tools, toys or other objects on the lawn that can damage the blades and cause the mower to stop.

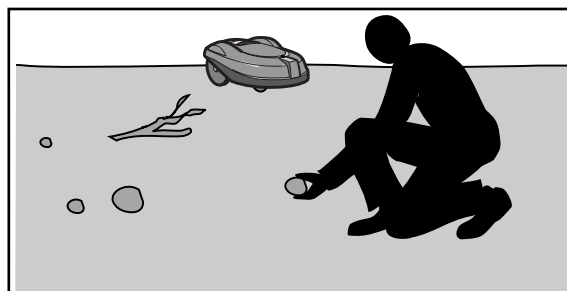

3012-275

- Start the Auto Mower according to the instructions. When the main switch is in the "ON" position; make sure you keep your hands and feet away from the rotating blades. Never put your hands and feet under the mower.



3012-274

- Never lift up the Auto Mower or carry it around when it is running.
- Do not let persons who do not know how the Auto Mower works and behaves use the mower.
- Do not put anything on top of the Auto Mower or its charging station.
- Do not allow the Auto Mower to be used with a defective blade disc or body. Neither should it be used with defective blades, screws, nuts or cables.
- Do not use the Auto Mower if the main switch does not work.
- Always switch off the Auto Mower using the main switch when you do not intend to use the mower.
- The Auto Mower must never be used at the same time as a sprinkler. In this case use the timer function, see "2. Timer" on page 30, so the mower and sprinkler never run simultaneously.

SAFETY INSTRUCTIONS

Transport

The original packaging should be used when transporting the Auto Mower over long distances.

To safely move from or within the working area:

1. Press the STOP button to stop the mower.

If the stop protection, (see page 36) used as to prevent theft, has been activated enter the first number of the PIN-code.

You select the four digit PIN code when you start the mower for the first time, see page 25.

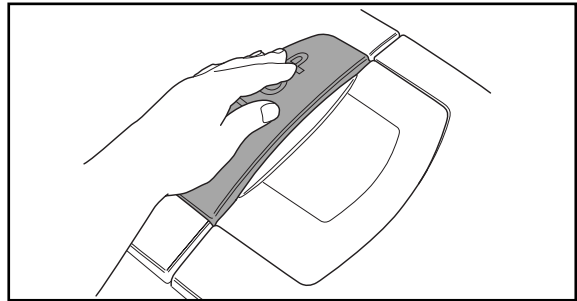

3012-247

2. Switch off the main switch if the mower is to be moved outside of the working area.
3. Carry the mower by the handle at the rear under the mower. Carry the mower with the top against your body.

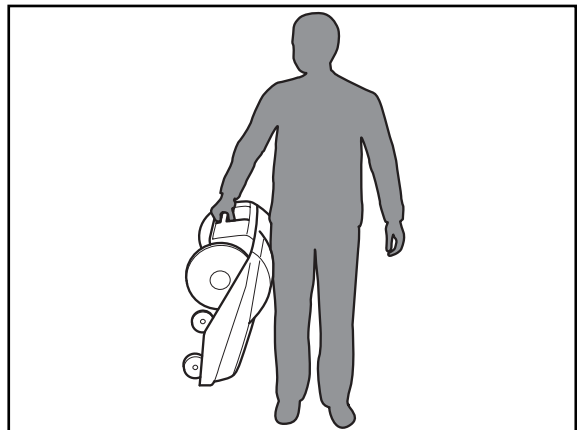

3012-261

Maintenance



WARNING

When the mower is turned upside down the main switch must always be set to the OFF position.

The main switch should be set to the OFF position with all work on the mower's underframe, such as cleaning or replacing the blades.

The beeps (5 beeps in 5 seconds) warn that the blade disc is about to start, if the beeps are not audible the Auto Mower is set to sound off.

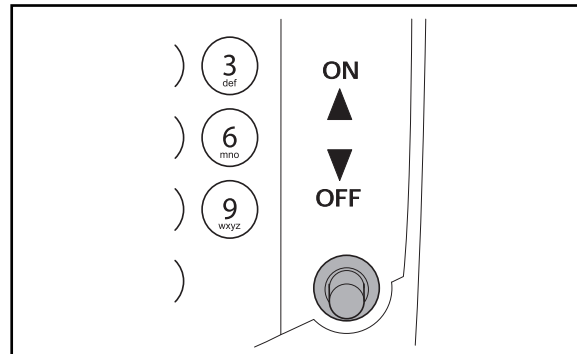

3012-250

- Inspect the Auto Mower each week and replace any damaged or worn parts.

Check especially that the blades and blade disc are not damaged. Replace all blade units at the same time if necessary so that the rotating parts are balanced, see "Maintenance" on page 43.

PRESENTATION

Presentation

Congratulations on your choice of an exceptionally high quality product.

To get the best from your Auto Mower requires knowledge of its function. This chapter contains information you should be aware of when planning the installation.

Installation of the Husqvarna Auto Mower includes four main components:

Auto Mower, an automatic lawn mower that mows the lawn by moving in essentially an irregular pattern. The mower is powered by a maintenance free battery

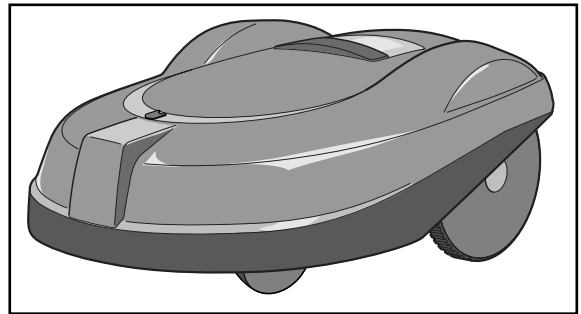

3012-278

Charging station, where your Auto Mower returns when the charge level in the battery becomes too low.

The charging station has three functions:

- To send control signals along the boundary wire.
- To send out signals so the Auto Mower finds the charging station.
- To charge the Auto Mower battery.

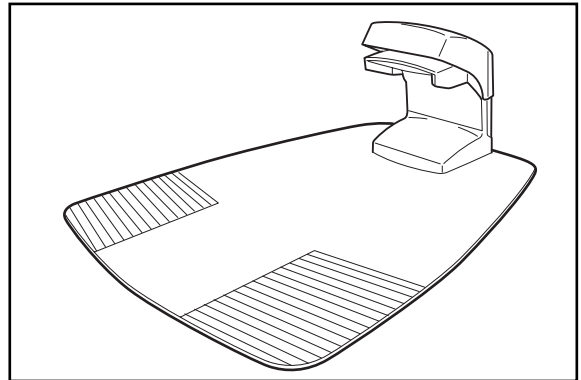

3012-216

Transformer, which is connected between the charging station and a 230 V wall socket. The transformer is connected to the wall socket via an integrated power cord and to the charging station via a 20 m long low voltage cable. The length of the low voltage cable must not be changed.

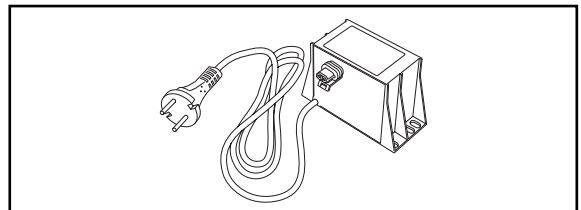

3012-220

Boundary wire, laid in a loop around the Auto Mower's working area. The wire is laid around the edges of the lawn and around objects and plants that the mower must not run into.

The length of boundary wire needed in an installation is the circumference of the working area plus a few extra metres to lay around "islands", objects and plants. A few extra metres are also required for any subsequent adjustments. The boundary wire supplied for the installation is 250 m long. If this is not sufficient more wire can be purchased, with a connector, and spliced onto the existing wire.

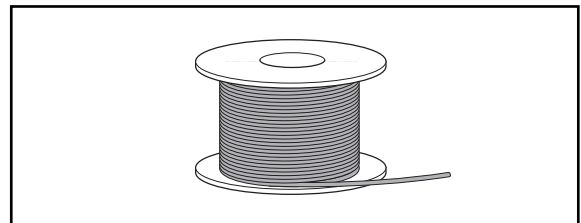

3012-221

PRESENTATION

Function Auto Mower

Working method

The Auto Mower automatically mows the lawn. It continuously combines mowing and charging.

When the Auto Mower works on a lawn, it simultaneously stores information about how the garden is shaped.

The charging station sends out a signal that the Auto Mower can sense at a distance of 6 - 8 metres. The mower starts to seek out the charging station when the capacity of the battery becomes too low. The Auto Mower does not mow when it is searching for the charging station.

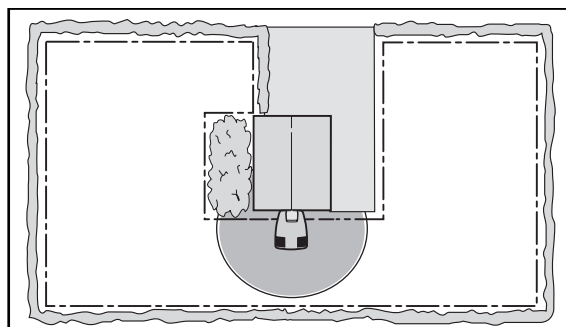

3012-233

When the battery is charged the mower reverses, turns around and leaves the charging station in a randomly selected direction within the exit sector 90° - 270° . Both the reversing length and exit direction can be set, see "3. Installation" on page 32.

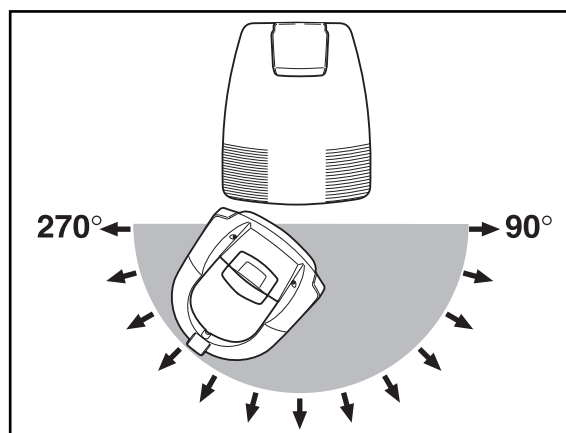

3012-225

When the Auto Mower body hits an obstacle, the mower reverses and selects a new direction.

Two sensors, front and back on the Auto Mower, sense when the mower approaches the boundary wire. The Auto Mower overruns the wire by up to 27 centimetres before it turns. The overrun length can be set, see "Drive past wire (3-2)" on page 34.

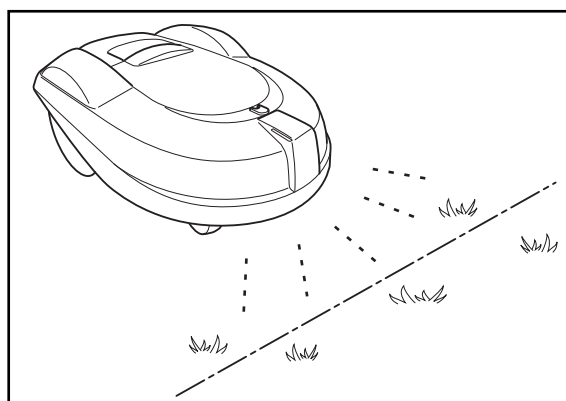

3012-226

PRESENTATION

The STOP button on the top of Auto Mower is mainly used to stop the mower when it's running. When the STOP button is pressed a cover opens, behind which there is a control panel. The STOP button remains depressed until the cover is closed again. This acts as start inhibitor.

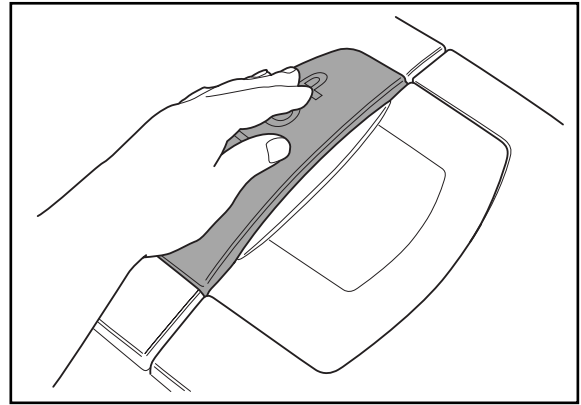

3012-247

The control panel on the top of the Auto Mower is where you manage all the mower settings. The main switch is also located on the control panel. Open the control panel cover by pressing down the STOP button.

When the main switch is turned ON for the first time, a start-up sequence begins which includes: selection of the language, time format, date format and the four digit PIN code as well as the setting of the time and date, see page 25.

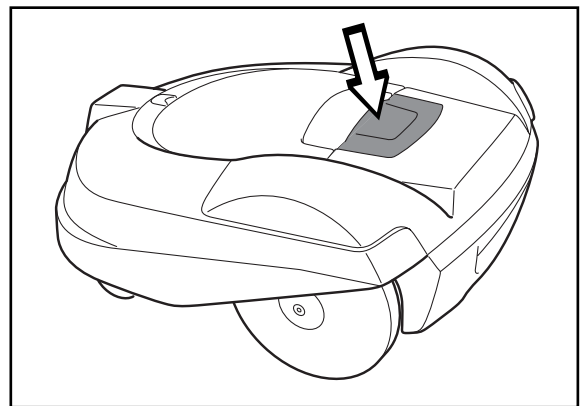

3012-283

The Auto Mower can enter a sleep mode to save power. The display on the control panel is then completely dimmed.

The sleep mode is activated 25 minutes after the STOP button has been pressed and then not reset to the operating mode. Auto Mower is then activated by switching the main switch off and on.

The sleep mode can also be activated in the event of a fault occurring during mowing or charging and which is not rectified within 25 minutes. The Auto Mower is then activated by pressing the STOP button.

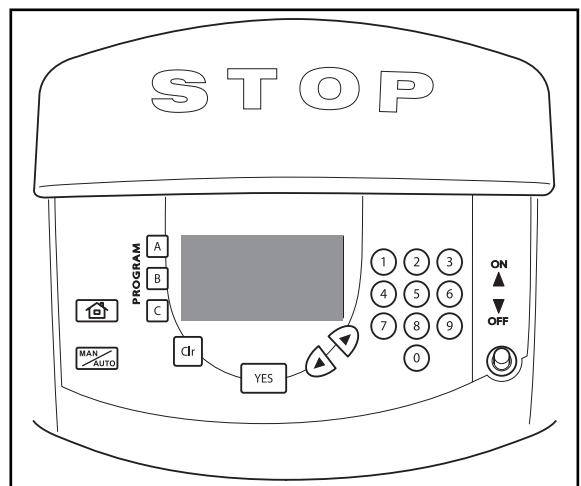

3012-297

PRESENTATION

Movement pattern

The mower's movement pattern is irregular and is determined by the Auto Mower itself. A movement pattern is never repeated. This mowing system means the lawn is mown equally without any mowing lines.

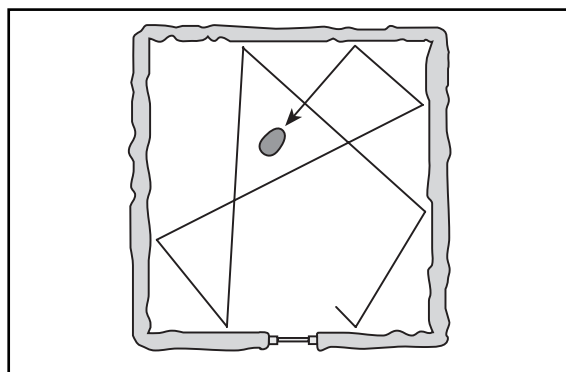

3012-276

If the Auto Mower enters an area where it senses the grass is longer than earlier, it can change the movement pattern. It can then mow in a square pattern to cover the area of longer grass more systematically. Thereafter the mower returns to the irregular movement pattern.

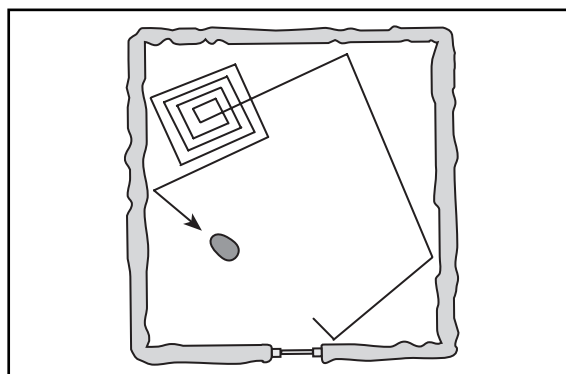

3012-277

Capacity

The Auto Mower is recommended for lawns up to 1800 m².

Auto Mower mows about 75 m² per hour. How large an area is mown depends primarily on the condition of the blades and the type of grass, growth rate and humidity. The shape of the garden is also significant. If the garden mainly consists of open lawns, the Auto Mower can mow more per hour than if the garden consists of several small lawns separated by many trees, flower beds and passages.

How long the Auto Mower mows respective charges can vary depending on, among others, the ambient temperature. Up to about 25°C a fully charged Auto Mower mows for approximately 60 - 90 minutes, depending on the age of the battery and the thickness of the grass. The mower then charges for about 60 minutes. Above 25°C both the mowing and charging times gradually drop.

INSTALLATION

Installation

This chapter describes how you install the Auto Mower.

Before starting the installation read the previous chapter "Presentation" on page 9 to page 12.

The installation should be carried out according to the following steps:

- A. Preparations.
- B. Planning the installation
- C. Placing the charging station.
- D. Charging the battery.
- E. Laying the boundary wire.
- F. Connecting the boundary wire.
- G. Checking the installation
- H. Linking the Auto Mower to the charging station.

The letters refer to the following headings.

A. Preparations

1. If the lawn in the working area is longer than 15 cm mow it using a conventional lawn mower. Then collect the clippings.
2. Read carefully through all steps before the installation.
3. Check that all parts for the installation are included:

The numbers in brackets refer to the detail diagram "Auto Mower, what is what?" on page 14.

- Operator's Manual (22)
- Auto Mower
- Charging station (14)
- Boundary wire in the right length (16)
- Transformer (17)
- Low voltage cable (18)
- Staples (19)
- Boundary wire connector (20)
- Boundary wire coupler (21)

During installation you will also need:

- Combination pliers
- Straight spade, if the boundary wire is to be buried

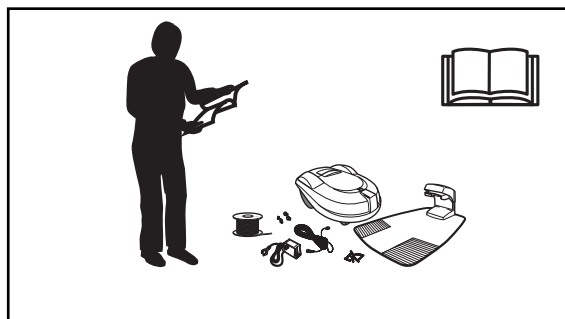

3012-301

INSTALLATION

Auto Mower, what is what?

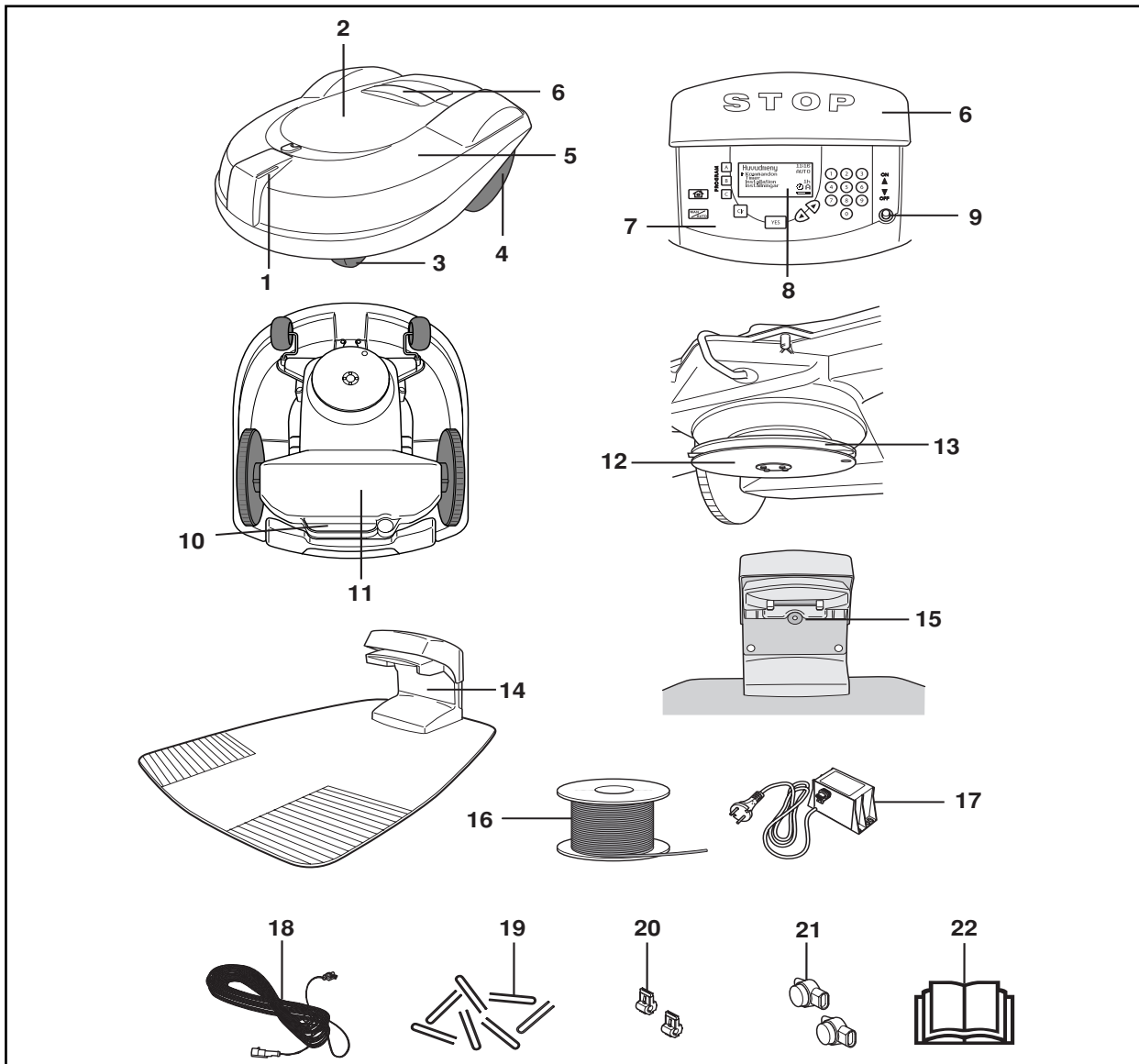

3012-224

The numbers in the picture corresponds to:

- | | |
|--|--|
| 1. Charging strip | 12. Skid plate |
| 2. Cutting height adjustment cover | 13. Blade disc |
| 3. Front wheel | 14. Charging station |
| 4. Drive wheel | 15. LED for operation check of the boundary wire |
| 5. Body | 16. Boundary wire |
| 6. Stop button | 17. Transformer with power cord |
| 7. Keypad | 18. Low voltage cable |
| 8. Display | 19. Staples |
| 9. Main switch | 20. Boundary wire connector |
| 10. Handle | 21. Boundary wire coupler |
| 11. Chassis box with electronics, battery and motors | 22. Operator's Manual |

INSTALLATION

B. Planning the installation

Charging station

First and foremost the charging station should be positioned:

- Centrally in the main area, along the outer edge and with a large free area in front of the station.

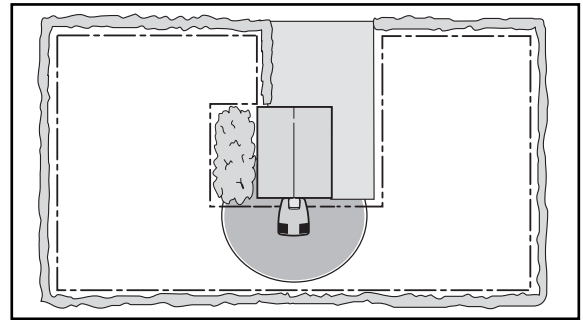

3012-233

- In the shadow. The battery is spared if it charged in the low possible ambient temperature.
- On relatively level ground. The height difference must not differ more than 10 cm between the front and rear of the charging station.

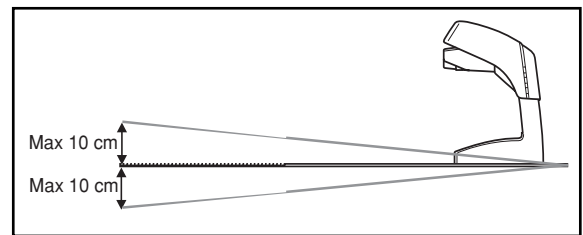

3012-296

- Close to a wall socket:

The charging station should be connected to a 230 V wall socket via the low voltage cable and transformer.

The supplied low voltage cable is 20 metres long.

IMPORTANT INFORMATION

The length of the low voltage cable must not be changed.

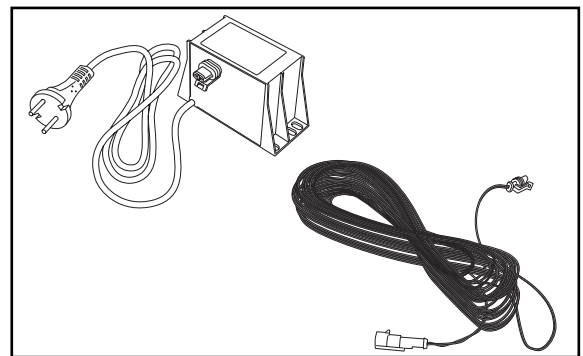

3012-220
3012-223

The transformer must be placed where it is well ventilated and is not exposed to direct sunlight. It is also beneficial if the transformer can be placed under a roof.

It is recommended to use an earth fault-breaker when connecting the transformer to the wall socket.

INSTALLATION

Plan the position of the charging station according to the shape of your garden.

The Auto Mower can be set for one of three basic garden shapes (see page 34).

The Auto Mower works differently depending on the garden shape the mower has been set to.

The available garden shapes are: open, complex 1 and complex 2.

The following pictures are examples of the different garden shapes. The pictures are also good examples of appropriate charging station placement.

- The open shape represents a lawn area with few obstacles and no passages.

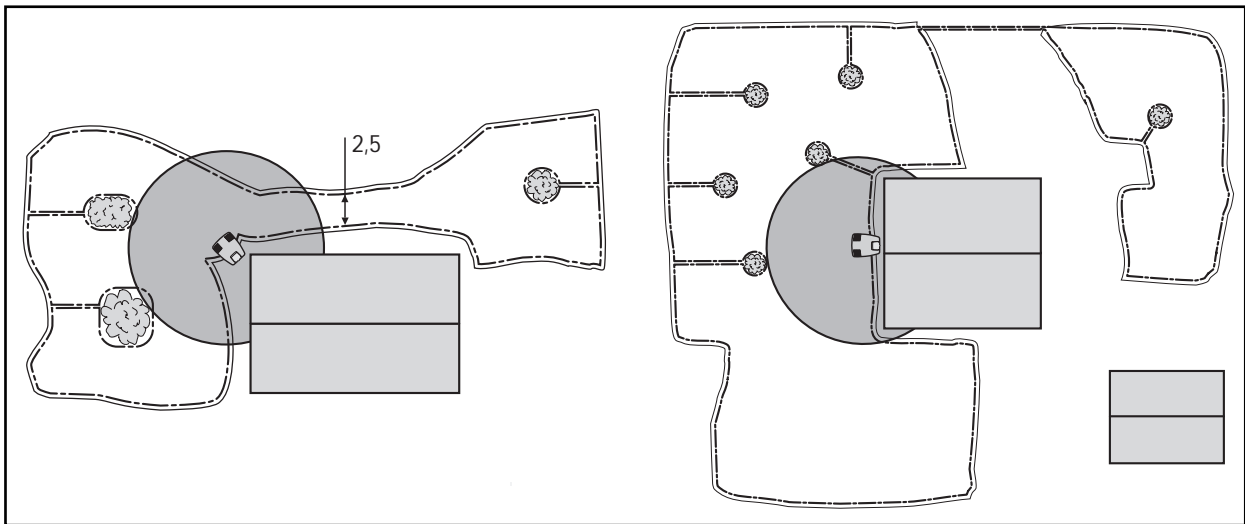

3012-290
3012-291

Example of the open garden shape. Lawn area 400 m² and 1100 m²

- Complex 1 is a large lawn area with an average amount of obstacles and passages.

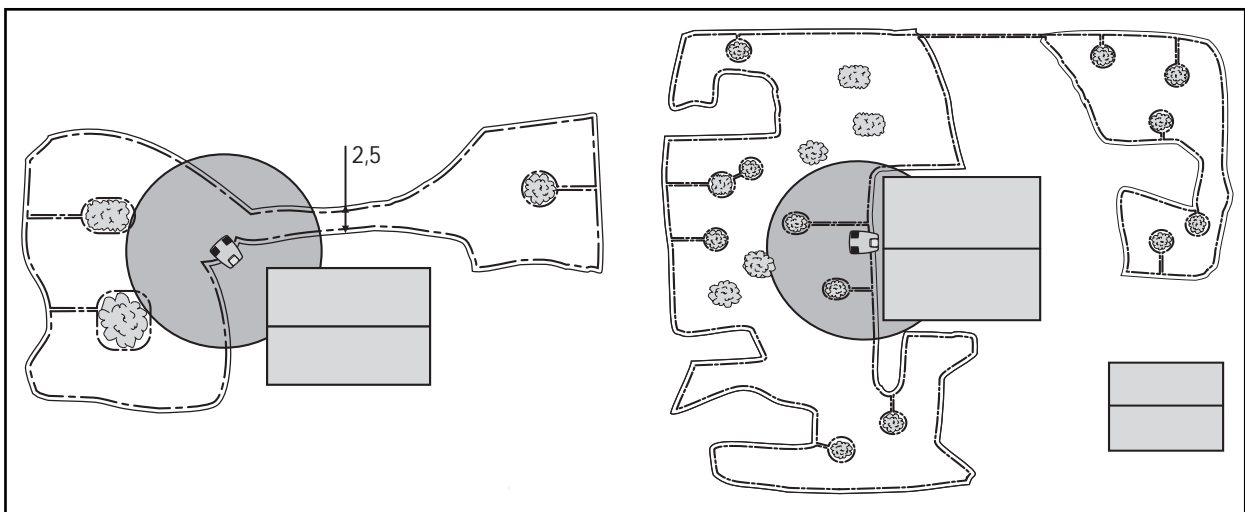

3012-292
3012-293

Example of complex 1 garden shape. Lawn area 900 m² respective 1000 m²

INSTALLATION

- Complex 2 is a large lawn area with many obstacles and passages.

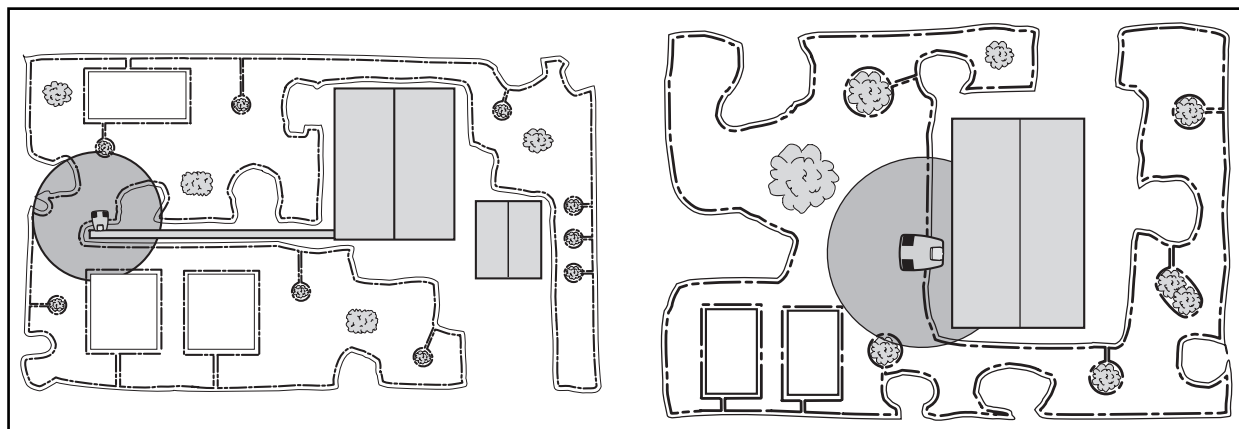

3012-294
3012-295

Example of complex 2 garden shape. Lawn area 1500 m² respective 800 m²

Do not put the charging station in a corner or pocket in the working area.

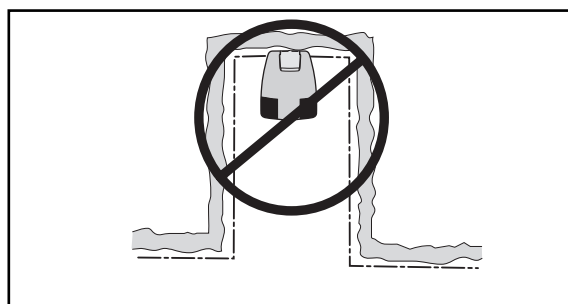

3012-235

If the garden consists of two large lawns joined by a passage, it may be difficult for the Auto Mower to find the entrance to the passage. Making it difficult to work efficiently in both areas. One way to make the mower effectively reach both areas is to position the charging station in the middle of the passage.

When the charging station needs to be placed in a passage, is it appropriate to manually set the exit direction, see "Charge exit settings (3-1)" on page 32. This will ensure both areas are mown equally and the grass close to the charging station will not appear down trodden.

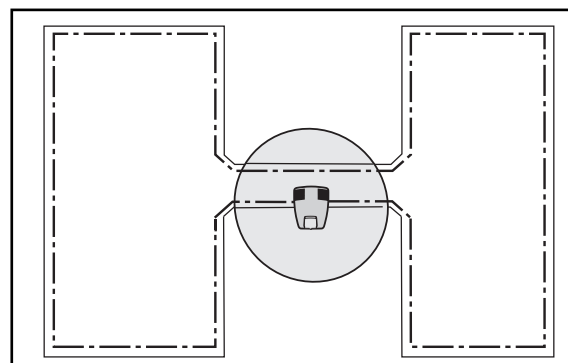

3012-237

INSTALLATION

Boundary wire

For a successful installation the placement of the boundary wire should be planned carefully. Planning is simplified if you make a sketch of the working area, including all obstacles. Draw how the boundary wire should be routed on the sketch.

The boundary wire should be laid so it:

- Forms a loop around the working area for the Auto Mower. Only Husqvarna boundary wire ought to be used. This is tinned and has a high quality insulation to withstand the dampness in the ground.
- Is a maximum of 500 metres long.
- Maintains a maximum distance of 35 metres from Auto Mower in the entire working area.
- Does not lie on a sharp incline. The Auto Mower may find it difficult to reverse back, especially in damp weather conditions, when there is a large risk of skidding.

Include the possibility in the planning that adjustments may need to be made to the loop. In doing so remember:

- Leave a few extra metres of wire at the beginning and end, close to the charging station.
- Place a few extra metres of wire about every 30 metres around the entire loop.

All extra wire should be laid in tight, parallel loops. If staples are used, the parallel loops should be placed under the same staple.

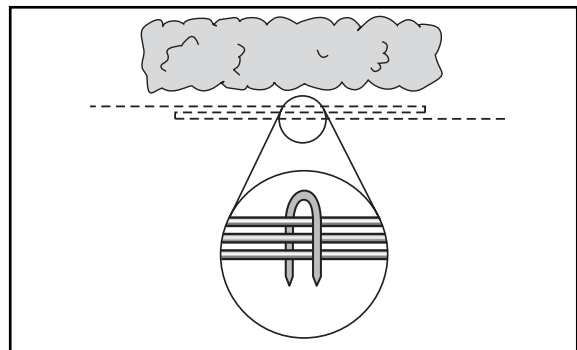

3012-138

IMPORTANT INFORMATION

Extra wire must not be placed in coils outside the boundary wire. This can disrupt the Auto Mower.

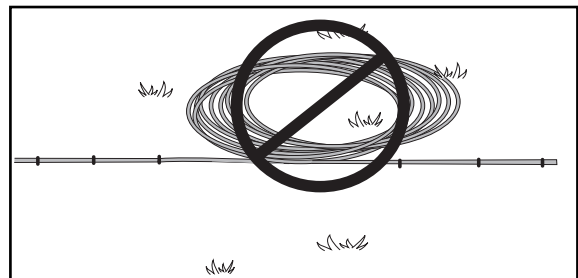

3012-281

INSTALLATION

Remember the following with regard to the working area boundaries:

- If a high obstacle, for example a wall or fence, borders the working area, the boundary wire should be laid 35 cm from the obstacle. This will prevent the Auto Mower from colliding with the obstacle and reduce body wear.

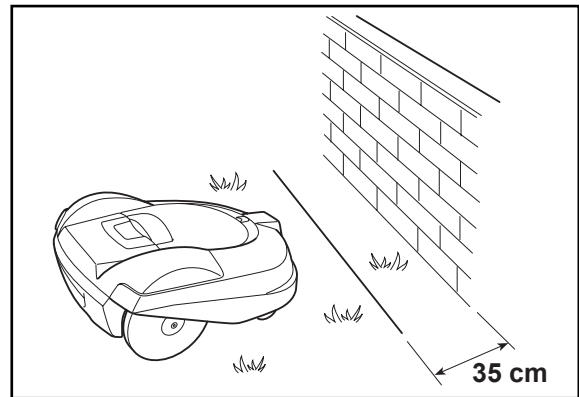

- If the working area borders against, for example, pools of water the boundary wire should be supplemented with a fence or the like. The height must then be at least 10 cm. This will prevent the Auto Mower, under any circumstances, coming outside of the working area.

- If the working area borders against a small ditch, for example, a flower bed or a small elevation, e.g. a low verge (3-5 cm), the boundary wire should be laid 30 cm inside the working area. This prevents the wheels from driving into the ditch or up onto the verge.

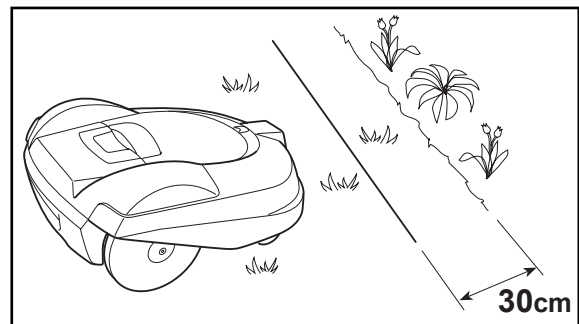

- If the working area borders against a flat path or the like that lies level with the lawn, it is possible to allow the Auto Mower to run a little over the path. The boundary wire should then be laid 10 cm from the edge of the path.

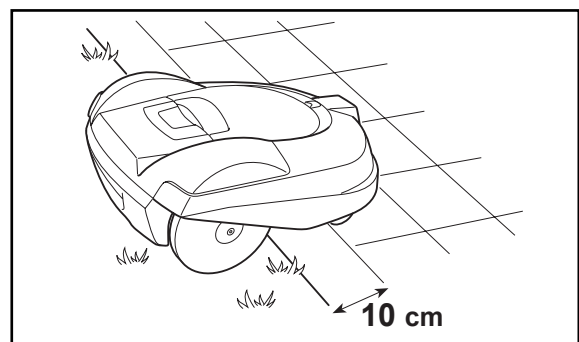

INSTALLATION

Remember the following with regard to the working area boundaries:

- The Auto Mower can mow areas with a gradient of up to 1:3 (33 cm/m) inside the working area. Areas that slope more must be demarcated by the boundary wire. If any part of the working area's outer edge has a gradient of 1:5 (20 cm/m) or more, the wire should be laid inside where the slope starts. The Auto Mower may find it difficult to turn at the loop where the ground slopes heavily.
- Use the boundary wire to demarcate areas inside the working area, for example, flower beds and fountains. Lay the cable up to the area, around it and then return along the same route. If staples are used, the cable should be laid under the same staple on the return route.

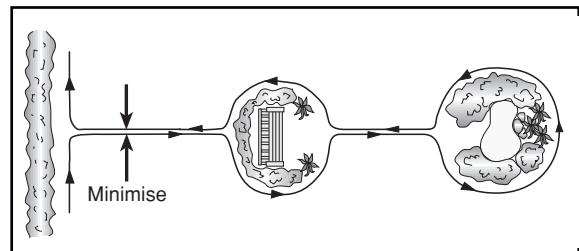

- Obstacles that can withstand a collision, for example, trees or bushes higher than 10 cm, do not need to be demarcated by the boundary wire. The Auto Mower will turn when it collides with this type of obstacle.

However, for the most gentle and silent operation, it is preferable to demarcate all fixed objects in and around the working area.

- Obstacles that slope slightly, for example, stones or large trees with raised roots, should be demarcated or removed. The Auto Mower can slide up onto this kind of obstacle causing the blades to be damaged.

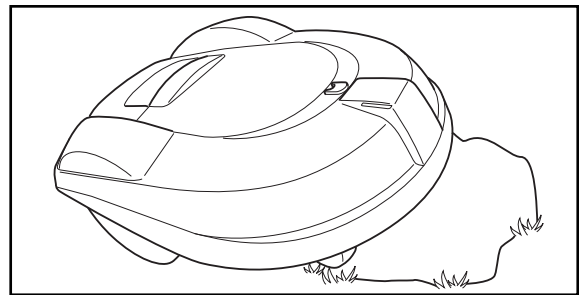

Remember the following with regard to secondary areas and passages:

- If there are secondary areas close to the main area the boundary wire should be laid so that these areas form an "island" outside of the main area.

Secondary areas are working areas without the charging station, but which are encircled by the same boundary wire as the main area. The Auto Mower must be moved manually between the main and secondary areas.

If the garden consists of two areas where one area is much smaller than the other and the areas are only connected by a very long narrow passage, it may be suitable to create a secondary area.

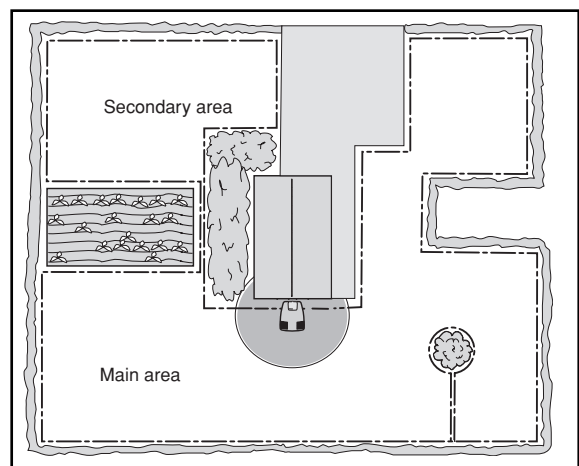

INSTALLATION

- In order for the loop system to work well, the wires in passages where the Auto Mower is to run through must not lie too close together.

A passage should be at least 2 metres wide so the Auto Mower can find it and make its way through it. The minimum spacing between the wires in a passage is 130 cm.

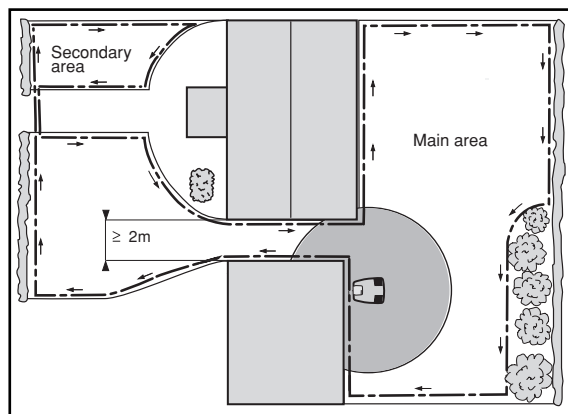

3012-232

The transition between a large area and a passage should be, if possible, designed like a "funnel", with rounded corners, to make it easier for the Auto Mower to enter the passage.

C. Placing the charging station

1. Place the charging station according to your plan.
2. Connect the low voltage cable to the charging station.

Only Husqvarna original cable and transformer may be used.

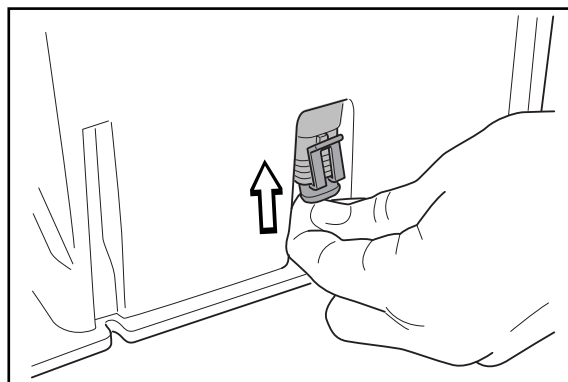

3012-263

3. Connect the low voltage cable to the transformer. The connectors may be a slightly difficult to connect, as they are moisture-proof.

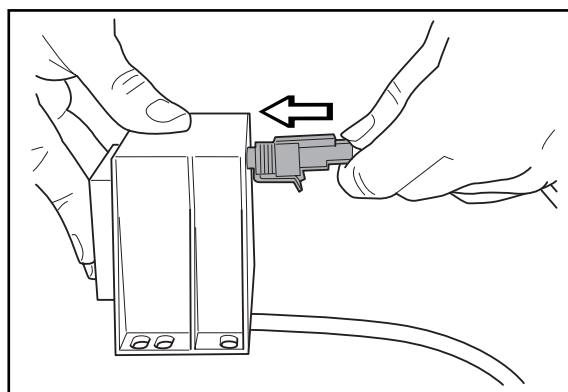

3012-262

4. Connect the transformer's power cord to a 230V wall socket. It is preferable to use an earth-fault breaker as recommended.

INSTALLATION

D. Charging the battery

The Auto Mower is supplied with an uncharged battery. As soon as the charging station is connected, it is possible to charge the mower.

1. Place the Auto Mower in the charging station to charge battery while you are laying the boundary wire.

Charging starts irrespective of the position of the main switch.

From an uncharged state the battery takes about 1 1/2 to 2 1/2 hours until it is fully charged.

If the Auto Mower leaves the charging station before the boundary wire is connected, the mower will stop in front of the charging station and show the fault message "No loop signal". This message automatic clears once the boundary wire is connected.

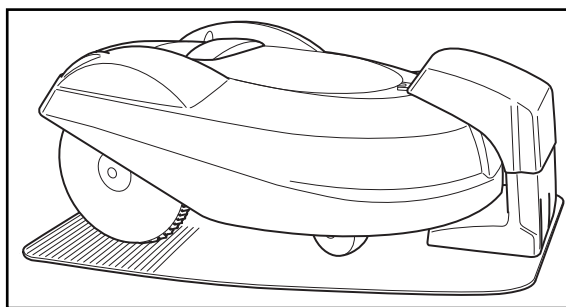

3012-238

E. Laying out the boundary wire

1. Lay the boundary wire according to your plan, but wait with the connection to the charging station.

Lay the cable by either:

- Securing the cable to the ground with staples. After a few weeks the grass roots will have grown over the cable so it is not visible.

It is important to secure the staples close together. The boundary wire must generally lie close to the ground so as not to be cut off before the grass roots have grown over it.

If you intend to install more than one Auto Mower in the same garden the different installations' boundary wires can be laid edge to edge with each other.

or:

- Bury the cable at a depth of 2-5 cm (maximum 20 cm).

If the boundary wire is not long enough and needs to be spliced: Use Husqvarna's solderless connector, part number 535 13 37-01. It is water-proof and gives a reliable electrical connection.

To splice: Insert both cable ends in the connector. Then press down the button on top of the connector.

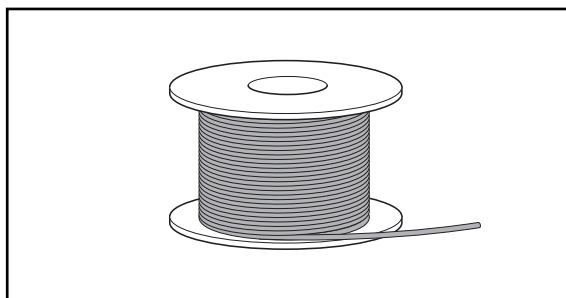

3012-221

IMPORTANT INFORMATION

Twisted cables, or a screw terminal ("chock-block"), insulated with insulation tape is not a satisfactory splice. Soil moisture will cause the conductors to oxidise and after a while result in a broken circuit.

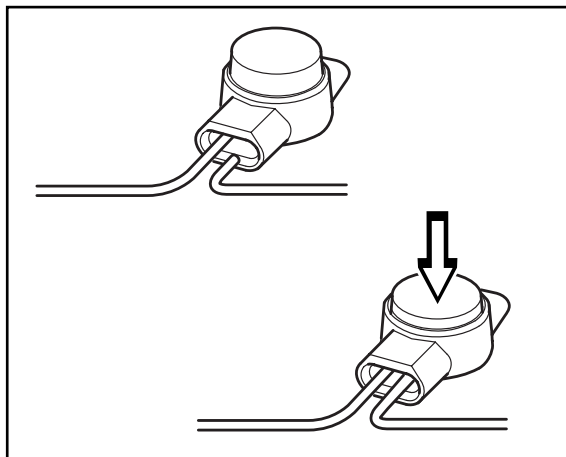

3012-304
3012-305

INSTALLATION

F. Connecting the boundary wire

Connect the boundary wire to the charging station:

1. Lift up the cover on the charging station:
 - Grip under the edge of the cover with both hands and pull straight out towards the sides.
 - Now lift the cover straight up.

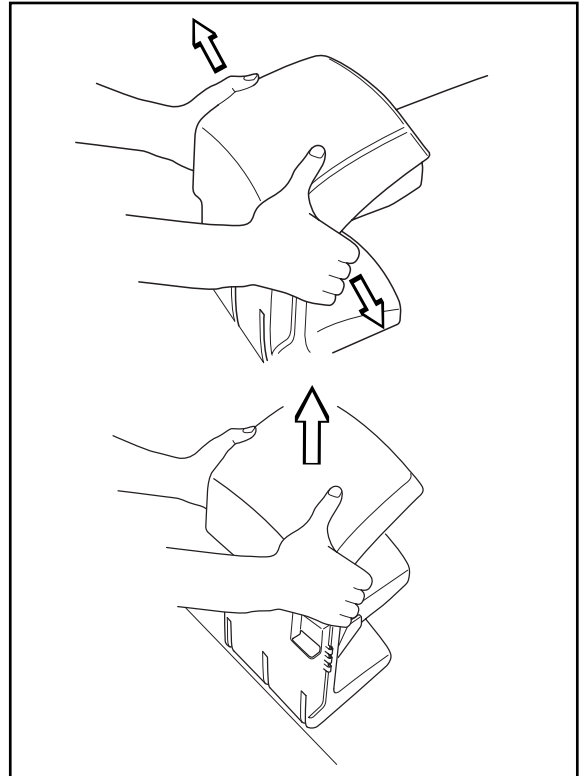

3012-268
3012-269

2. Slide in the ends of the boundary wire in the lowermost holes on the charging station and catch them in the uppermost holes.

The right hand wire end should be inserted in the right hand hole and the left hand wire end in the left hand hole.

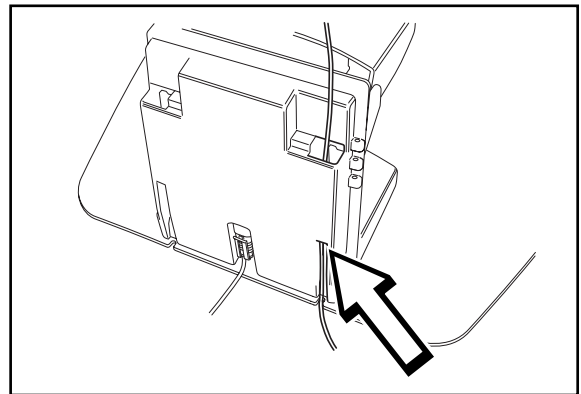

3012-266

IMPORTANT INFORMATION

The boundary wire must not be crossed when connecting to the charging station. Therefore the right hand wire end must be connected to the right hand connector on the charging station and vice versa.

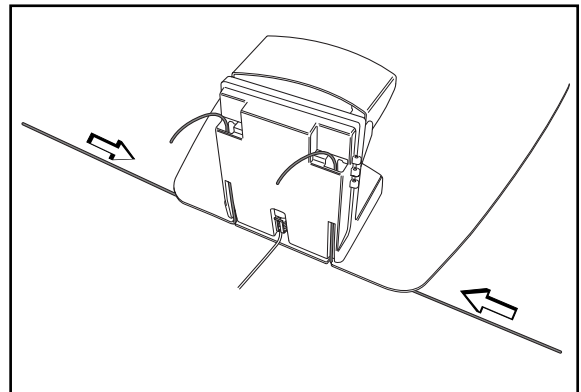

3012-303

INSTALLATION

3. Place the cable ends in the connector:

- Open the connector.
- Place the wire in the connector grip.

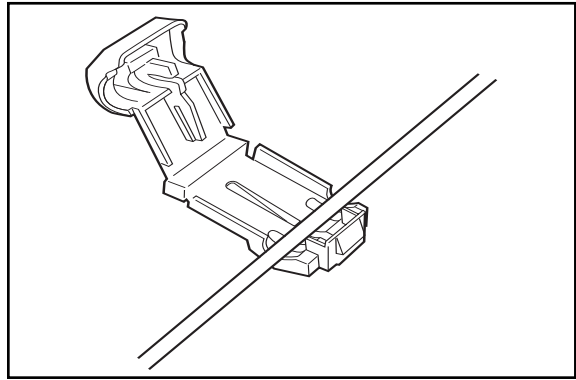

3012-284

4. Press the connector together using a pair of pliers. Press until you hear a click.

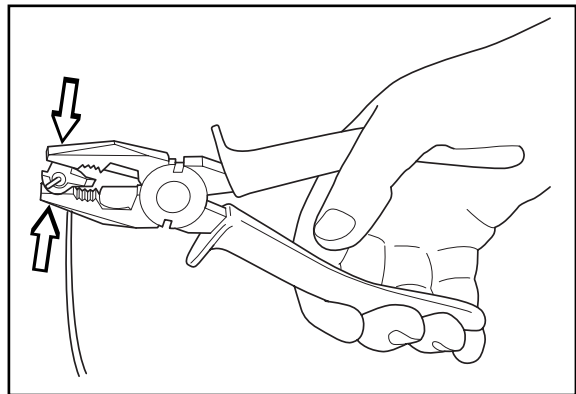

3012-264

5. Cut off any surplus boundary wire. Cut 1-2 cm above respective connectors.

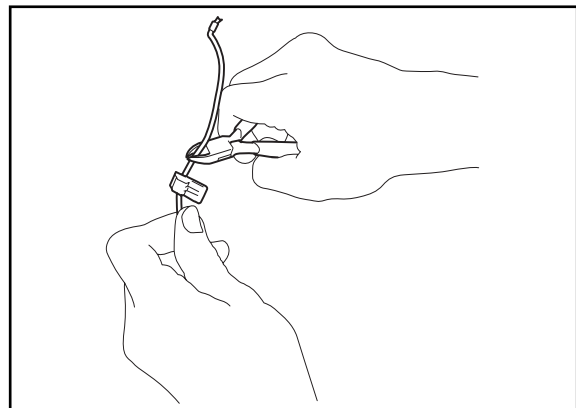

3012-265

6. Press the connector onto the metal pin on the charging station.

IMPORTANT INFORMATION

The right hand connector should be connected on the right hand metal pin on the charging station and vice versa.

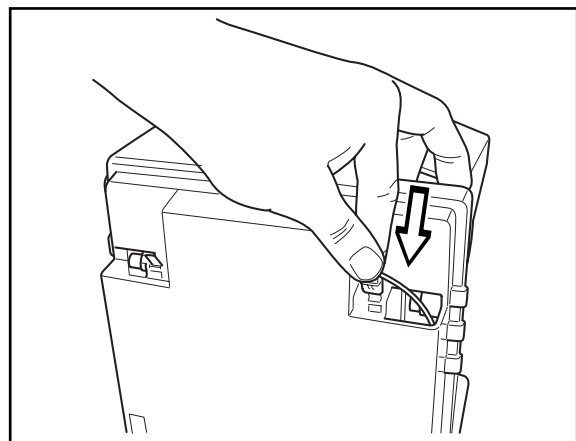

3012-267

INSTALLATION

7. Refit the cover on the charging station. Ensure the three guides on the charging station enter the right holes in the cover.

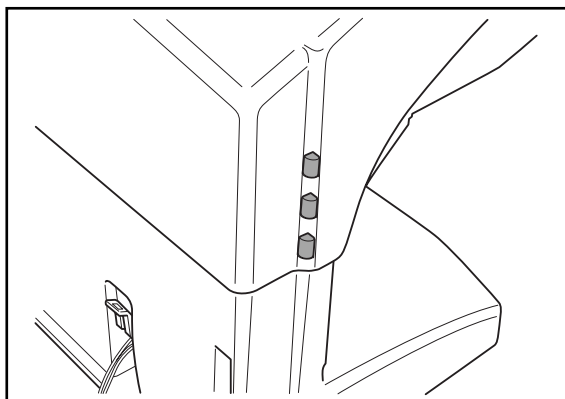

3012-270

G. Checking the installation

Check the loop signal by looking to see what indication the green LED on the charging station is giving.

- Lit =
the signal is okay.
- Single flashing every other second =
break in the loop and no signal found.
- Double flashing every other second =
signal found, but the wire is probably damaged.
Check all wire connections.

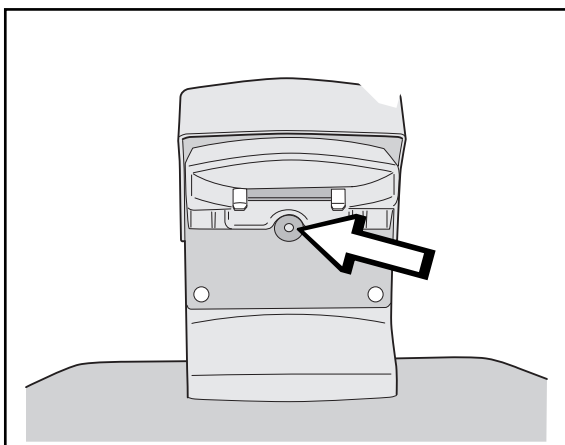

3012-282

H. Linking the Auto Mower to the charging station

1. Open the control panel cover.
2. Set the main switch to the ON position.
A start-up sequence begins when the Auto Mower is started for the first time. The following is requested: Language, time format, correct time, date format and correct date.
3. Place the Auto Mower in the charging station.
4. State the four digit PIN code. All combinations except 0000 are permitted.

If you own more than one Auto Mower and charging station in the same garden, each mower must have its own PIN code.

If you have one Auto Mower for several gardens with one boundary wire and charging station per garden the mower can have the same code for all gardens. The distance between the boundary wire loops must be at least 20 cm.

When you have chosen a PIN code with the Auto Mower placed in the charging station, the mower and charging station are then linked to each other.

CONTROL PANEL

Control panel

On the top of the Auto Mower there is a control panel under a cover. Open the cover by pressing the STOP button. Close the cover by sliding it forward until a click is heard. The click is heard when the STOP button returns to the operating mode.

All forms of commands and settings for the Auto Mower are made via the control panel. All functions are accessed via a number of menus.

The control panel consists of a display and a keypad. All information is shown on the display and all entry is done using the buttons.

The main page shows the main menu, cursor, clock, selected operating mode, number of mowing hours, clock icon, program selection and battery status.

- The main menu is the uppermost level in the entire menu structure.
- The cursor shows which menu has been selected when the YES button is pressed.
- The clock shows the current time.
- The text AUTO or MAN shows which operating mode has been selected.
- The number of operating hours indicates the number of hours since the day of manufacture that the Auto Mower has been in operation. The time that the Auto Mower has spent mowing or looking for the charging station is counted as operating time.
- The clock icon shows when the Auto Mower should be or is switched off by the timer, i.e. stands in the charging station or is on its way to the charging station to switch off.
- The program icon shows when one of the programs under the buttons A, B or C is selected.
- The battery status shows the remaining battery charge.

The keypad consists of five groups of buttons: Shortcuts, program, selection, numbers and the main switch.

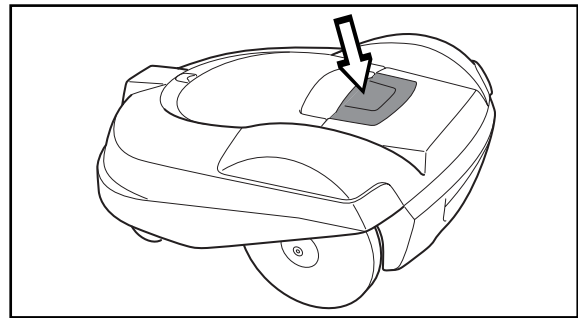

3012-283

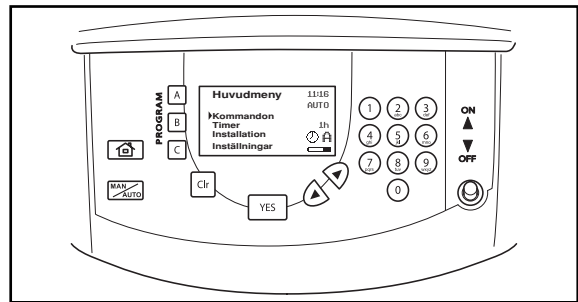

3012-285

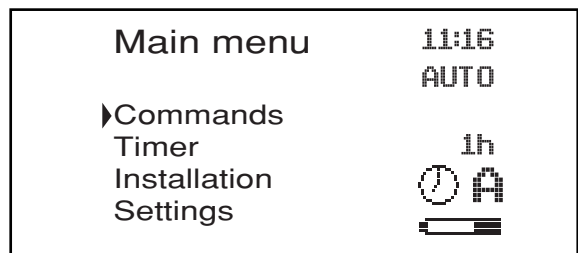

3012-286

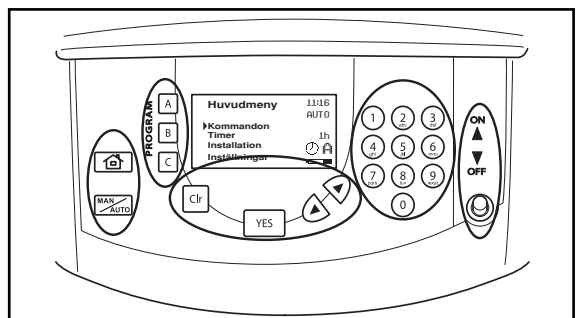

3012-239

CONTROL PANEL

Shortcuts

1. Home:
 - Sends the mower to the charging station. Where it stays until the button is pressed again.
The house icon is lit on the right-hand side of the display when the button is pressed.
 - Move the cursor in the menu structure back to the main page.

2. Operating mode:

The selected operating mode is shown on the right-hand side of the display as AUTO respective MAN.

Press the button to choose between:

- **AUTO**, the normal automatic operating mode where Auto Mower mows and charges continuously.
- **MAN**. If you select MAN and close the control panel cover when the Auto Mower is on the lawn, it will mow until the battery is discharged. It will then stop and show the message "Battery empty". The mower must then be moved manually to the charging station and then started manually after charging.

If you select MAN and close the control panel cover when the Auto Mower is in the charging station the mower will charge completely, reverse 20 centimetres and stop.

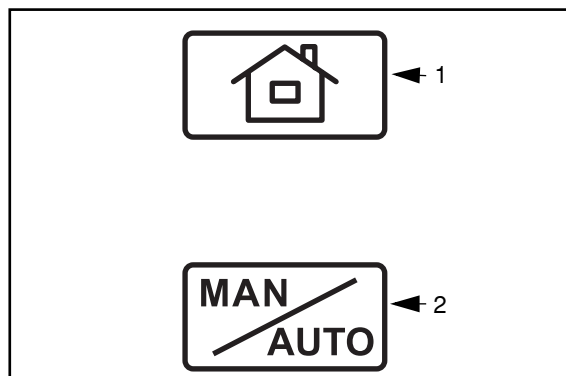

3012-240

Program

3. A
4. B
5. C

Under the program buttons you can save sets of different settings, to reuse or to simplify the use of an Auto Mower in several gardens. Under respective buttons are some preset settings. You can choose to use these or change them.

- To change settings: Make the required settings. Save by holding down the selected button for 2 seconds, until two beeps are heard close together. If, for example, button A is pressed the message "Program A changed" will be shown for 2 seconds on the display.
- Use the saved information by quickly pressing the required button.

If, for example, button A is pressed the question "Use program A?" will appear on the display. If YES is pressed, the message "Program A selected" will be shown for 2 seconds on the display. The letter "A" is then shown on the right-hand side of the display to indicate which program is selected.

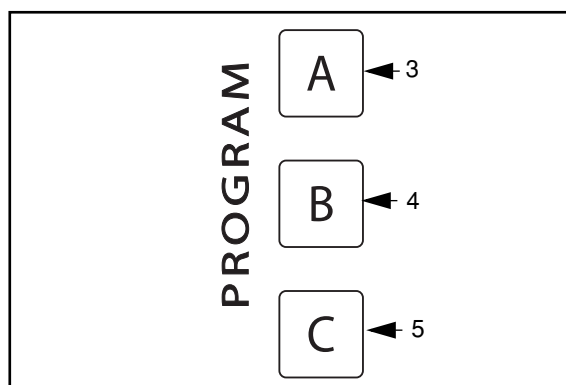

3012-241

CONTROL PANEL

Select

6. Clr:
 - Press to go back one step in the menu structure.
7. YES
 - Press to confirm an entry or selection.
 - Press to start the mower if more than 10 seconds has elapsed since you last pressed a button and you want to close the control panel cover.
8. Arrows
 - Press any of the arrow buttons to browse between menus or different selections.

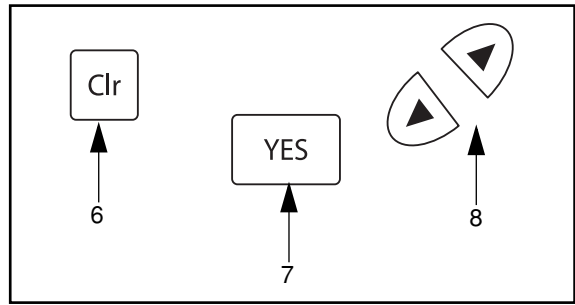

3012-242

Numbers

9. Used in the menu structure to enter settings, for example, PIN code, time or exit direction.
Also used to state a number series as a shortcut to the different menus. See more about number series in "Number series" on page 29.

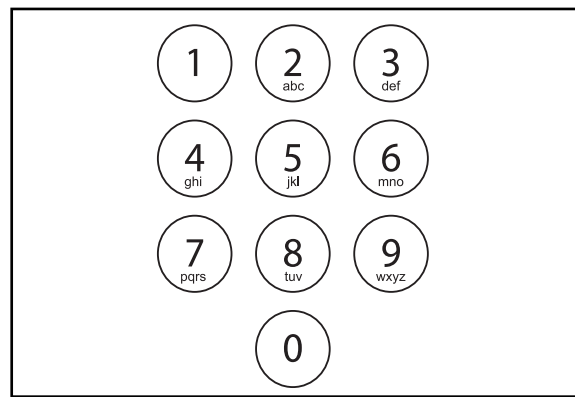

3012-243

Main switch

10. Set the main switch in the "ON" position to start the Auto Mower.
Set the main switch in the "OFF" position when you are not using the mower or if you want to work on the blade disc.
When the main switch is set in the "OFF" position the motors on the mower cannot start.
When the main switch is turned ON for the first time, a start-up sequence begins which includes: selection of the language, time format, date format and four digit PIN code as well as setting of the time and date, see page 25.

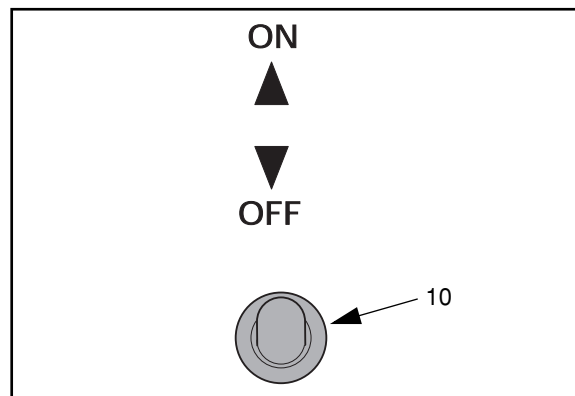

3012-244

MENU FUNCTIONS

Menu functions

Main menu

The main menu consists of four options:

1. Commands
2. Timer
3. Installation
4. Settings

The numbers refer to the headings on the coming pages.

There are a number of submenus under each option. You can access all the functions to set the Auto Mower settings via these.

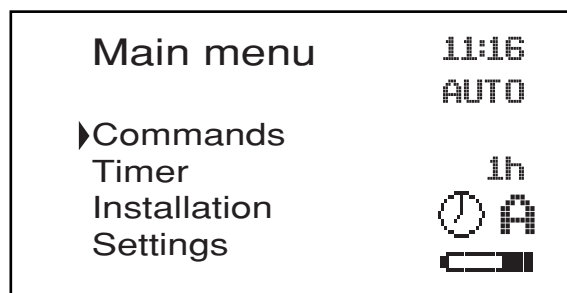

3012-286

Browse between menus

Browse through the main menu and submenus with the help of the arrow buttons. Enter values and the time with the help of the numerical buttons and confirm each selection with the YES button. Press the Clr-button to move one step back and press the Home button to return directly to the main menu.

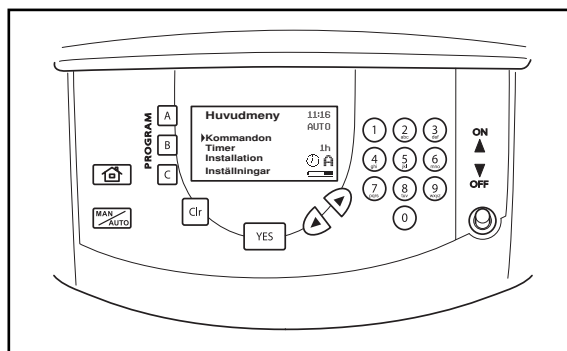

3012-285

Number series

The selection you have made in the main menu as well as subsequent selections made in submenus are shown as a number series in the right hand corner of the display.

The first number in the series refers to the selection in the main menu. The second number refers to the first sub-menu, etc. The displayed number series can consist at most of three numbers.

You can use the number series as a shortcut to reach a specific function directly. For example: Press 2 2 in the main menu and the sub-menu "Day timer" is shown.

The headings on following pages include respective number series within brackets.

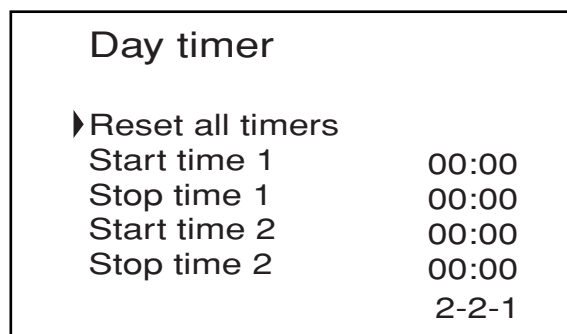

3012-287

Submenus

In some of the submenus there is a box to the right of specific rows. When this box is checked with a tick it means the function is selected.

In some of the submenus there is information to the right of specific rows. This information indicates which selection has been made for the function.

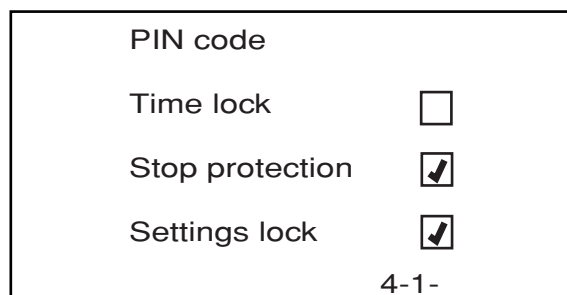

3012-307

MENU FUNCTIONS

1. Commands

Via this selection in the main menu you access the main Auto Mower functions. Select among the sub-menus:

- **Charge then AUTO (1-1)**
in order for the Auto Mower to drive immediately to the charging station, charge the battery and then return to the automatic operating mode. Select the function and press YES when the cursor is on "Yes".
- **Show latest faults (1-2)**
to show the list of saved fault messages. Browse with the arrow buttons. The list can contain up to 20 fault messages and each message is shown with the date and time.
- **Reset factory settings (1-3)**
to restore all settings to their original values. Everything except the language, PIN code and the settings under the buttons A, B and C are reset. Select the function, state your PIN code and press YES when the cursor is on "Yes".
- **Reset ABC settings (1-4)**
to delete all programming made under the buttons A, B and C. Select the function and press YES when the cursor is on "Yes".

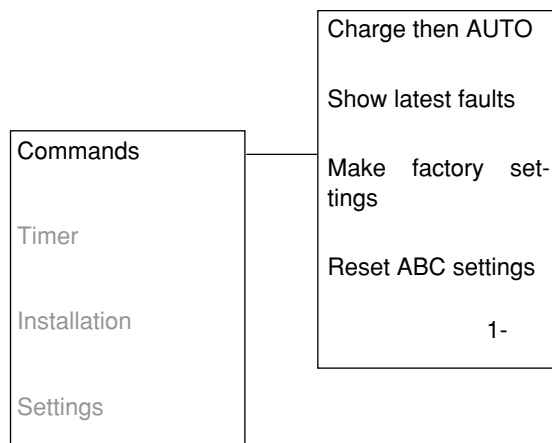

2. Timer

Via this option in the main menu you access the timer settings. Select among the submenus:

- **Timer override (2-1)**
to temporarily disconnect the timer function.
- **Day timer (2-2)**
to set the start and stop times.
- **Weekend timer (2-3)**
to set the start and stop times for the days Friday - Sunday.
- **Week Timer (2-4)**
to select which days of the week the Auto Mower should mow.

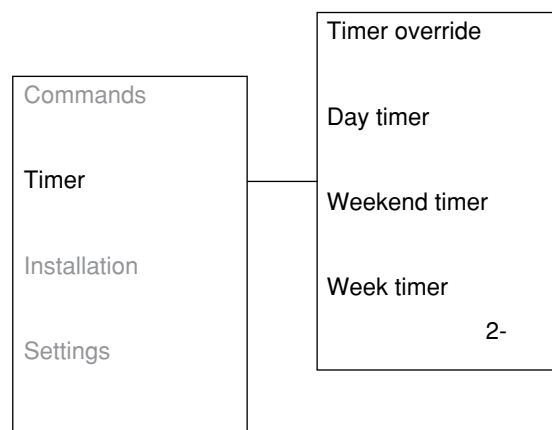

Timer override (2-1)

If you set the timer on your Auto Mower you can use this function to temporarily get maximal operation from the mower.

- **ON (2-1-1)**
Move the cursor to "ON" and press YES to turn off the timer function.
- **OFF (2-1-2)**
Move the cursor to "OFF" and press YES to turn on the timer function.

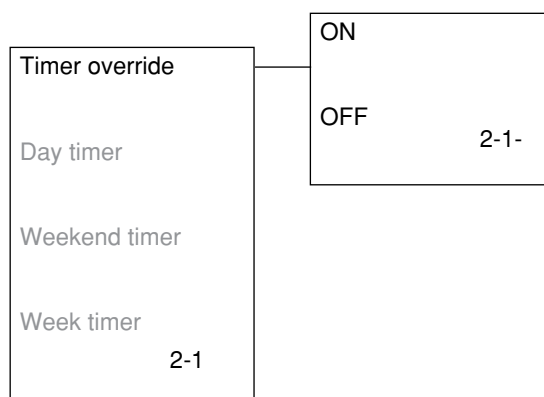

MENU FUNCTIONS

Day timer (2-2)

It is possible to set two different start and stop times for each day. Enter the required time in hours and minutes.

- Reset all timers (2-2-1)
To delete all set times: Select the function and press YES when the cursor is on "Yes".
- Start time 1 (2-2-2)
- Stop time 1 (2-2-3)
- Start time 2 (2-2-4)
- Stop time 2 (2-2-5)

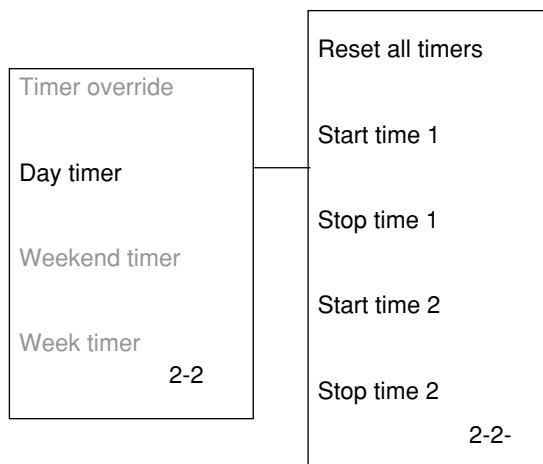

Weekend timer (2-3)

- Reset all timers (2-3-1)
To delete all set times: Select the function and press YES when the cursor is on "Yes".
- Start time 1 (2-3-2)
- Stop time 1 (2-3-3)
- Start time 2 (2-3-4)
- Stop time 2 (2-3-5)
- Copy from day timer (2-3-6)
Press YES when asked "Copy?" to transfer all times set in the day timer.



Week Timer (2-4)

Use the YES button to select the days you would like the Auto Mower to mow.

- Mon (2-4-1)
- Tue (2-4-2)
- Wed (2-4-3)
- Thu (2-4-4)
- Fri (2-4-5)
- Sat (2-4-6)
- Sun (2-4-7)
- Run all (2-4-8)

Move the cursor to "Run all" and press YES. Then press YES again to the question "All ON".

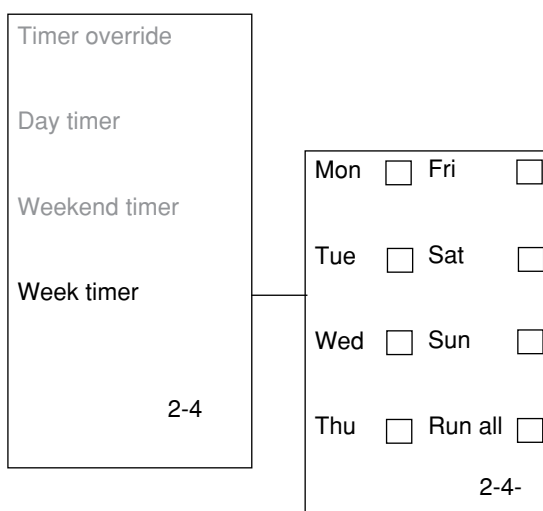

MENU FUNCTIONS

3. Installation

Via this option in the main menu you access the driving settings. Select among the submenus:

- **Charge exit settings (3-1)**
to set how far the Auto Mower should reverse out of the charging station before it turns and in what direction the mower should leave the charging station.
- **Drive past wire (3-2)**
to set the distance over the boundary wire that the Auto Mower should drive.
- **Garden shape (3-3)**
to tell the Auto Mower which type of garden you have.
- **Check loop (3-4)**
to check that the loop is intact or exactly where in the lawn the wire is.

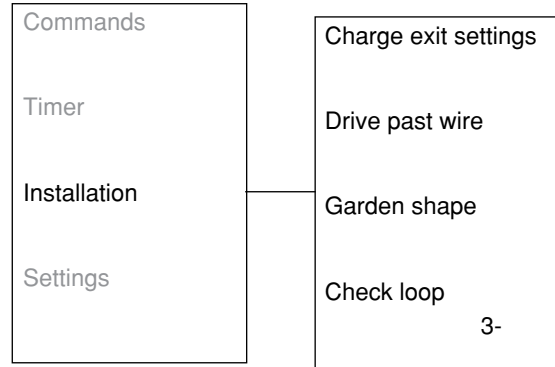

Charge exit settings (3-1)

Normally the Auto Mower leaves the charging station in a direction within the exit sector 90° - 270° , where 90° is called the begin angle and 270° is called the end angle. By manually setting the exit direction you can control how the Auto Mower should leave the charging station. If the charging station is located in a passage you can get the best access to all lawns by using this function.

Auto Mower can be set for one or two exit sectors.

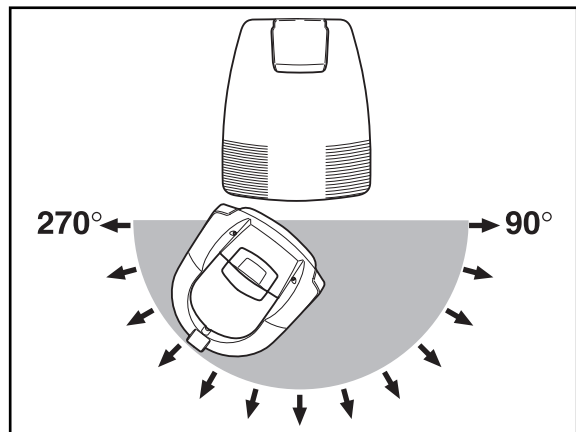

3012-225

Use begin and end angle 1 in the menu "Customized" if you want to use one sector.

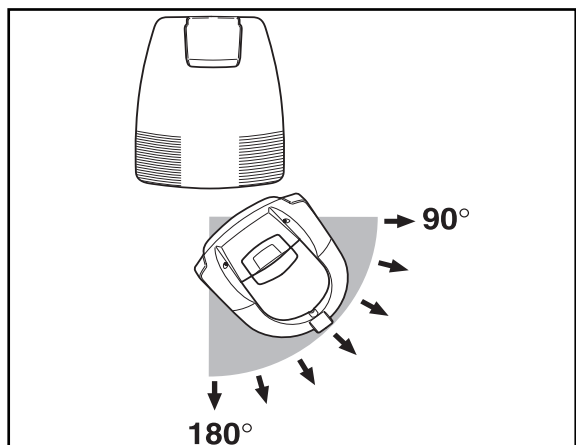

3012-245

MENU FUNCTIONS

Also use begin and end angle 2 in the menu "Customized" if you want to use two sectors.

Use the function "Proportion first" as well to state a percentage to determine how often the Auto Mower should leave the charging station in sector 1. For example, the percentage 75% means the mower will leave the charging station in sector 1, 75% of the time and in sector 2, 25% of the time.

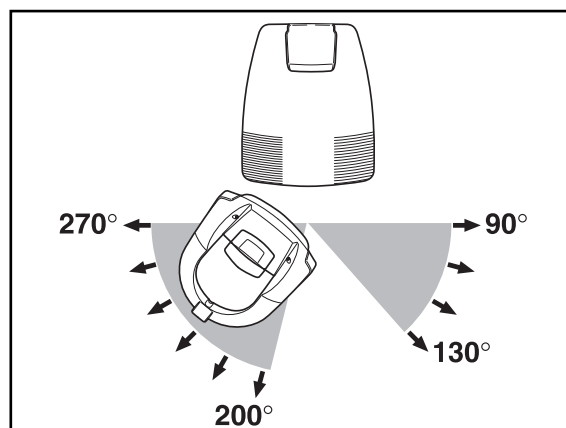

3012-246

- Automatic (3-1-1)

In order for Auto Mower to follow the preselected exit settings: Move the cursor to "Automatic" and press YES. Then press YES again to the question "Reset to default?".

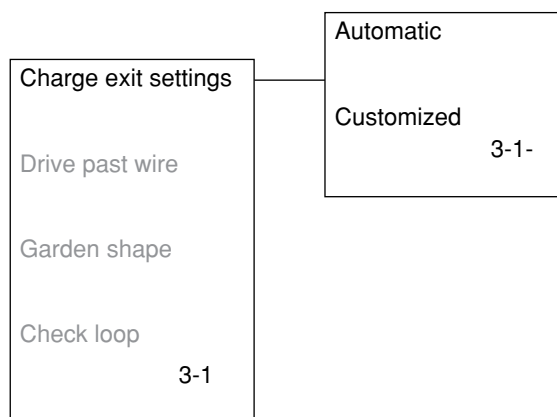

- Customized (3-1-2)

- Reversing dist.

State the number of centimetres you want the Auto Mower to reverse before it turns to drive out of the charging station.

The default reversing distance is 60 cm.

- Begin angle 1

State in degrees where you want the sector/sector 1 to start.

- End angle 1

State in degrees where you want the sector/sector 1 to end.

- Begin angle 2

State in degrees where you want the sector/sector 2 to start.

- End angle 2

State in degrees where you want the sector/sector 2 to end.

- Proportion first

When you use two exit sectors: State a percentage to define on how many occasions the Auto Mower should leave the charging station in sector 1.

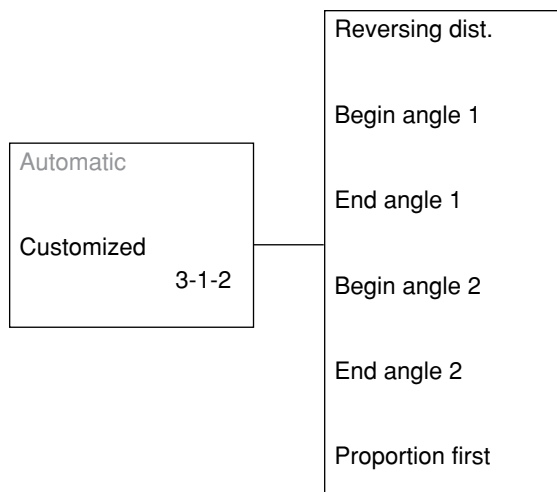

MENU FUNCTIONS

Drive past wire (3-2)

The front of the Auto Mower always passes the boundary wire by a specific distance before the mower turns. The default distance is 27 cm, but this can be changed if required.

- To adjust the distance: Move the cursor to "Drive past wire" and press YES. Now state the number of centimetres you want the Auto Mower to pass the boundary wire.

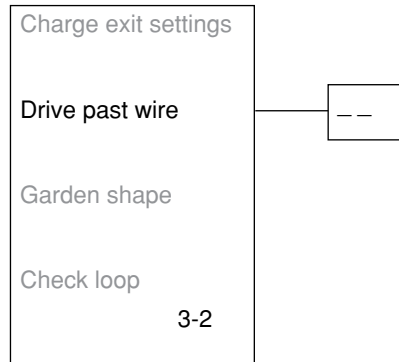

Garden shape (3-3)

The Auto Mower can be set according to three garden shapes: open, complex 1 and complex 2. See examples of garden shapes on page 16. Many gardens can be characterised as open, which is also the default setting on the Auto Mower.

- Open (3-3-1)
Select "Open" if your garden has an open lawn, few obstacles and no passages.
- Complex 1 (3-3-2)
Select "Complex 1" if your garden has an average number of obstacles and/or passages.
- Complex 2 (3-3-3)
Select "Complex 2" if you garden has a large lawn and many obstacles and/or passages.

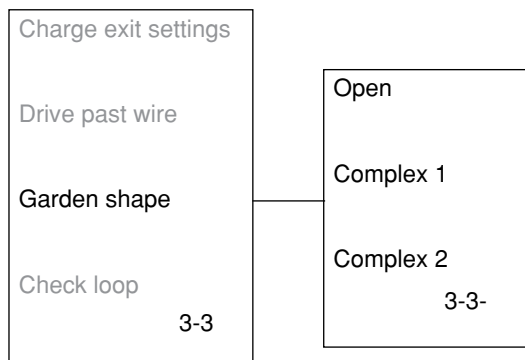

Check loop (3-4)

This function allows you to check the mower's signal reception from the boundary wire, and to determine exactly where in the lawn the boundary wire is routed.

The sensor used for this function sits concealed directly under the catch button for the cutting height adjustment cover. The sensor detects the position of the Auto Mower in relation to the loop. "Inside", "Outside" or "No loop signal" are shown on the display. If the mower is inside the loop, "Inside" is shown, etc. If the mower is set with sound on, a constant beep is also heard when the mower is outside and a pulsating beep when it cannot detect a signal. If the mower is inside the loop no beep is heard.

To:

- Check the signal reception: Move the cursor to "Check loop" and press YES.
- Find wire: Move the Auto Mower over the outer edge of the working area and select "Check loop". Repeat until you find the boundary between "Inside" and "Outside". You now know where the wire is.

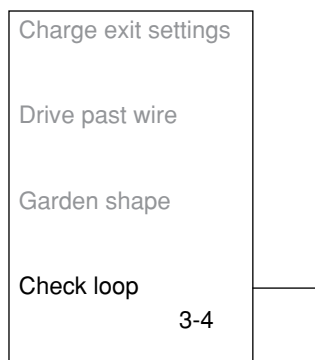

MENU FUNCTIONS

4. Settings

Via this option in the main menu you access the available settings. Select among the submenus:

- **Security (4-1)**

to make settings concerning the PIN code, stop protection, settings lock and alarms. The PIN code must be stated for the "Security" menu to be shown. All security and theft protection functions must be activated manually when Auto Mower is new.

- **Sounds (4-2)**

to adjust the sound level for the functions blade start-up, operation, charging, fault messages and keypad.

- **User info level (4-3)**

to determine the level of detailed for information shown on the display when Auto Mower is operational.

- **Language (4-4)**

to select the menu language.

- **Time and date (4-5)**

to set the current time and day as well as the require time and date format.

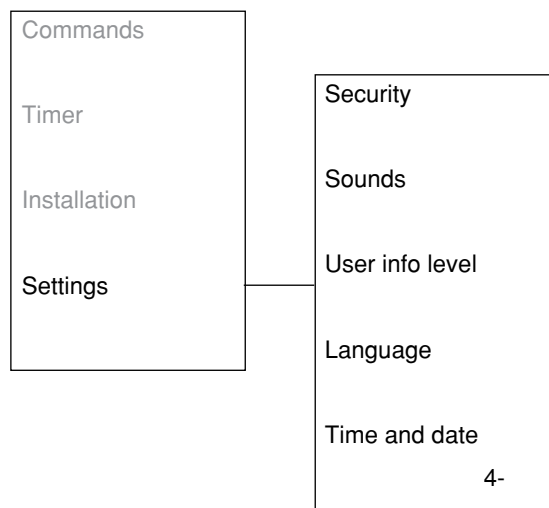

Security (4-1)

- PIN code (4-1-1)

Via this function you can change your PIN code at any time.

- To change the PIN code: Move the cursor to "PIN code" and press YES. Place the Auto Mower in the charging station. Enter the new PIN-code and press YES. Enter the same code again to confirm and press YES.

When the PIN-code has been changed, the message "PIN-CODE CHANGED" is displayed for a few seconds. The "Security" menu will then appear again.

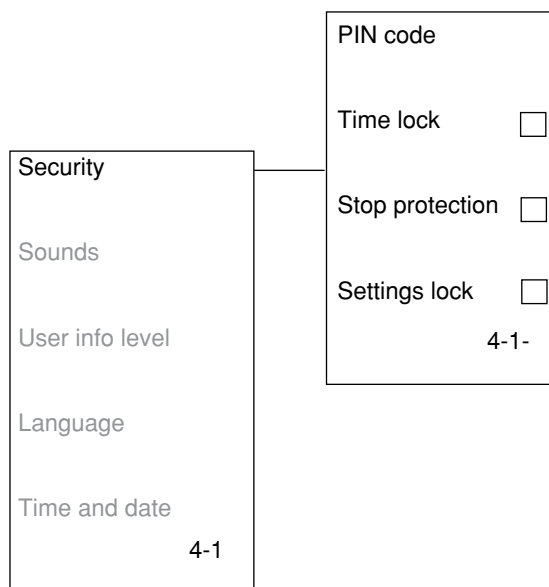

MENU FUNCTIONS

- Time lock (4-1-2)

This function partly involves the Auto Mower stopping to mow after a predetermined number of days and not continuing until the correct PIN code has been entered, and partly that the PIN-code must be entered when the main switch is set to the ON position.

To:

- Activate: Move the cursor to "Time lock" and press YES. Now Move the cursor to "Number of days" and press YES. State how many days you would like the Auto Mower to mow before it requests the PIN-code. Finish by pressing YES.

When the chosen number of days have passed, the Auto Mower completes its mowing, charges the battery, reverses out of the charging station and stops. The message "Enter PIN code" is shown on the display. You then enter your code and press YES.

- Deactivate: Move the cursor to "Time lock" and press YES. Now move the cursor to "OFF" and press YES.

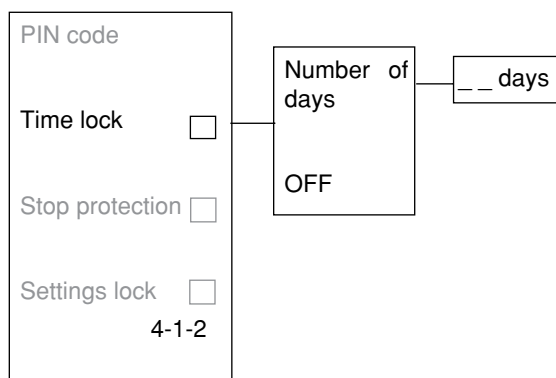

- Stop protection (4-1-3)

This function entails the first number of the PIN-code needing to be stated within 10 seconds after the STOP button has been pressed. If the correct number is not entered after three attempts, the alarm sounds. The alarm can then be stopped by entering the complete PIN-code.

To:

- Activate: Move the cursor to "Stop protection" and press YES. Select "ON" to activate and press YES. Now respond to the question "How many minutes should the alarm sound?", by stating the number of minutes.

- Deactivate: Move the cursor to "Stop protection" and press YES. Select "OFF" to deactivate and press YES.

When you select "OFF", the alarm function is also deactivated.

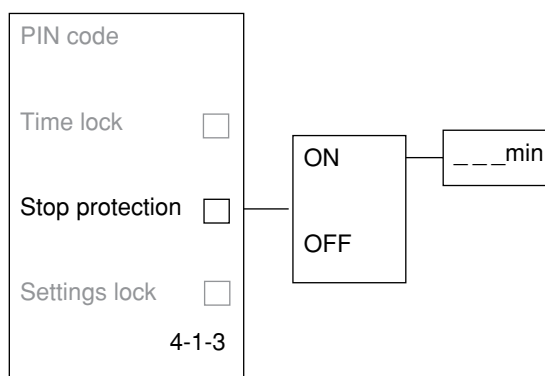

- Settings lock (4-1-4)

This function prevents any one who does not know the PIN-code from making or changing any of the settings. It also prevents the A, B or C programs from being selected or saved.

To:

- Activate: Move the cursor to "Settings lock" and press YES. Now select "On" to activate.
- Deactivate: Move the cursor to "Settings lock" and press YES. Now select "Off" to deactivate the function.

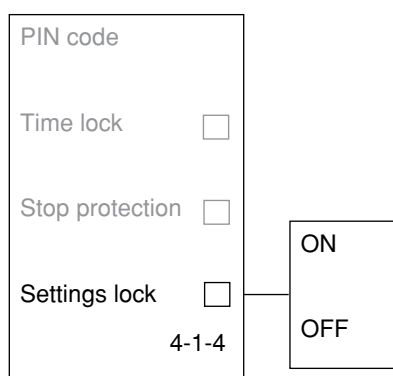

MENU FUNCTIONS

Sounds (4-2)

A number of audio messages are used to indicate what the Auto Mower is currently doing. The sound levels are graduated from level 4 (highest) to OFF (completely quiet).

- Default (4-2-1)

where the sound level is OFF on all functions except blade start-up and keypad where the sound level is set to 2.

- Move the cursor to "Default" and press YES. Now press YES when asked "Set default sound?".

- All quiet (4-2-2)

means that the sound level for all functions is set to OFF, except the keypad which is set to sound level 1.

- Move the cursor to "All quiet" and press YES. Now press YES to the question "Set quiet sound?".

- All high (4-2-3)

means all functions are set to sound level 3.

- Move the cursor to "All high" and press YES. Then press YES to the question "Set high sound?".

- Customized (4-2-4)

Use "Customized" if you wish to set different sound levels for the different functions.

- To customize: Move the cursor to "Customized" and press YES. Now select the respective function, press YES, move the cursor to the required sound level and finish by pressing YES.

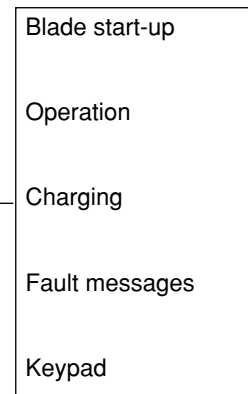
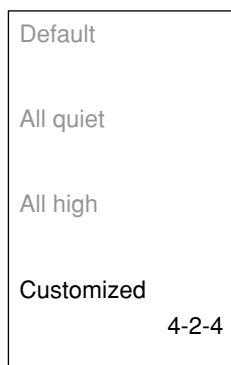
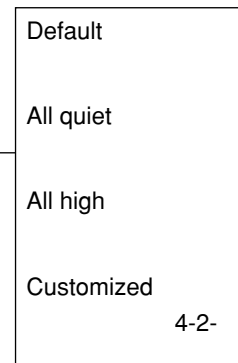
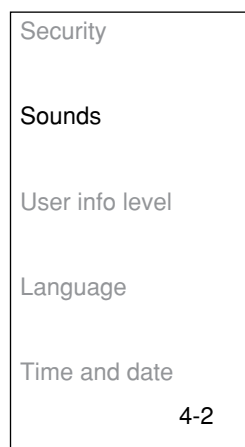

When the Auto Mower is set to sounds on, an audio message is heard according to what the mower is currently doing.

| Sounds | Significance |
|-----------------------------|---|
| 2 beeps/10 seconds | Charging |
| 1 beep/10 seconds | Mowing/searching |
| 1 beep/second for 5 seconds | Starting blade |
| 3 beeps/second | Fault message |
| On long beep | Blade disc blocked |
| Short click sound | A button on the keypad has been pressed |
| Short double beep | A change to the setting has been made |
| Muffled long beep | Incorrect input |

MENU FUNCTIONS

User info level (4-3)

Selecting the user info level involves determining how much information should be shown on the display when the main switch is set in the ON position. The basic user info level means less information on the display than in the advanced user info level.

To select:

- Basic (4-3-1)
 - Move the cursor to "Basic" and press YES.
- Advanced (4-3-2)
 - Move the cursor to "Advanced" and press YES.

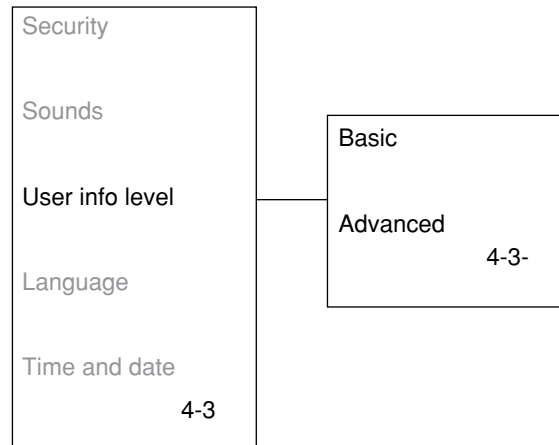

The table below shows the information messages shown on respective user info levels.

| Information message | Basic user info level | Advanced user info level |
|---------------------------------------|-----------------------|--------------------------|
| STARTING | X | X |
| CHARGING | X | X |
| Charge time (min) | | X |
| Current charge (mA) | | X |
| MOWING | X | X |
| Mow time (min) | | X |
| Cutting power | | X |
| SEARCHING | X | X |
| Mow time (min) | | X |
| Search time (min) | | X |
| TIMER | X | X |
| FAULT (for example, "No loop signal") | X | X |
| STATE PIN to CANCEL ALARM | X | X |
| WAITING | X | X |

MENU FUNCTIONS

Language (4-4)

Using this function you can change the language selection you made when the Auto Mower was first started.

To select the language: Move the cursor to "Language" and press YES. Now Move the cursor to the required language and press YES.

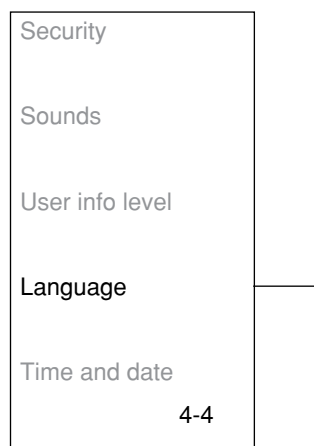

Time and date (4-5)

Using this function you can change the time and date on the Auto Mower.

You can also change the format selections you made when the Auto Mower was first started via this function.

- Set time, 4-5-1

Move the cursor to "Set time" and press YES. Now state the correct time and finish with YES.

- Set date, 4-5-2

Move the cursor to "Set date" and press YES. Now state the correct date and finish with YES.

- Time format, 4-5-3

Move the cursor to "Time format" and press YES. Move the cursor to the required time format:

- 12h or
- 24h.

Finish by pressing YES.

- Date format, 4-5-4

Move the cursor to "Date format" and press YES. Move the cursor to the required date format:

- YY-MM-DD (year-month-day),
- MM-DD-YY (month-day-year) or
- DD-MM-YY (day-month-year).

Finish by pressing YES.

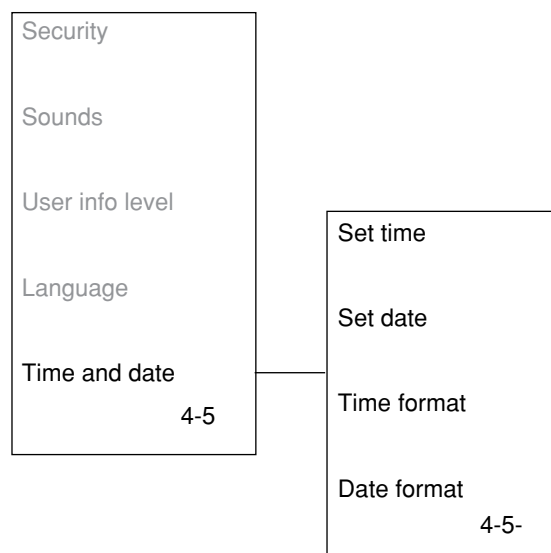

USE

Use

Charging a discharged battery

When the Auto Mower is new or has been stored for a long period the battery will not be charged and needs to be charged before starting. Charging takes between 1 1/2 and 2 1/2 hours.

1. Place the Auto Mower in the charging station. Make sure the charging strips on the mower makes good contact with the contact strips on the charging station.

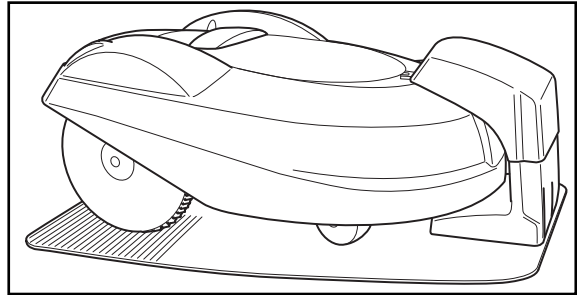

3012-238

Good contact is made when both charging strips lie against the centre of the contact strips.

2. Open the control panel cover.
3. Set the main switch to the ON position.

Information about the charging process is shown on the display during the entire charging process.

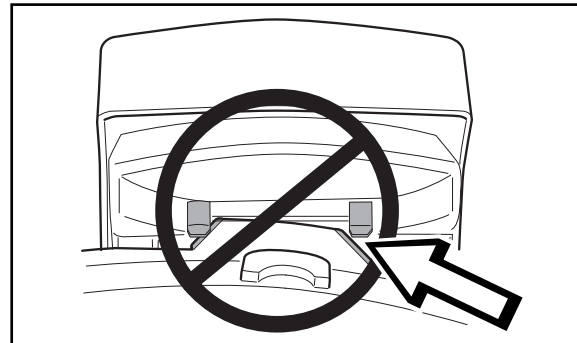

3012-299



WARNING
Read the safety instructions before you start your Auto Mower.

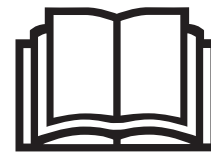

1001-003



WARNING
Keep your hands and feet away from the rotating blades.

Never put your hands or feet close to or under the body when the motor is running.



3012-274

Starting the Auto Mower

1. Press the STOP button to open the control panel cover.
2. Set the main switch to the ON position.
If the time lock is activated: Enter the PIN-code.
3. Close the cover.

The message "STARTING" is shown on the display. If the Auto Mower is set with the sound on you will also hear 1 beep/second for 5 seconds when blade disc starts.

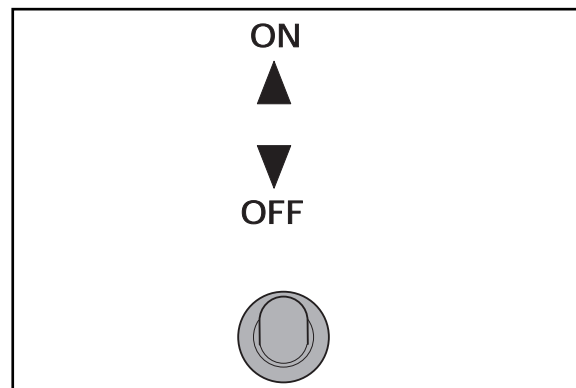

3012-244

Using the timer

Mow the lawn as much as you like when you like. Use the timer function (see "2. Timer" on page 30) to avoid a down trodden lawn and to get the maximum life from your Auto Mower.

For example, the quality of your lawn will improve if it is mown every other day instead of 12 hours each day. In addition, the grass benefits from resting completely during at least a three day period once a month.

Stopping the Auto Mower

1. Press the STOP button.
The Auto Mower stops, the blade motor stops and the control panel cover opens.

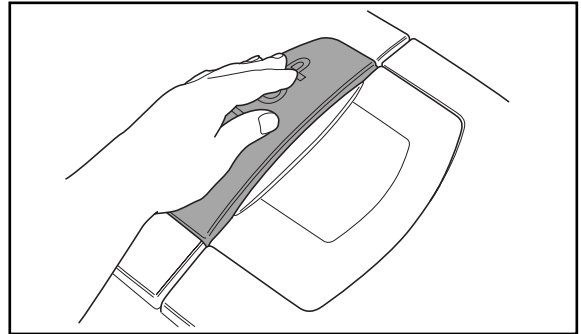

3012-247

Restart

Restart within 10 seconds:

1. Close the control panel cover.
The Auto Mower starts automatically.

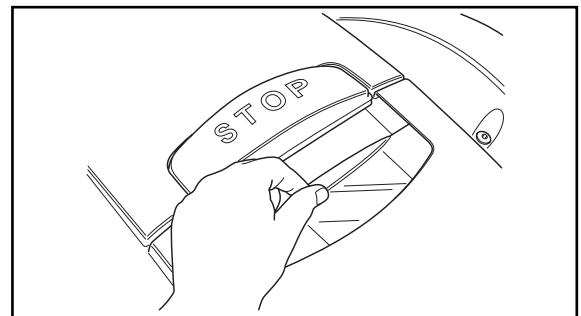

3012-248

Restart after more than 10 seconds:

If more than 10 seconds has elapsed since the last time the STOP button or the keypad was pressed it is not possible to start the Auto Mower by just closing the cover.

To start:

1. Press the YES button.
2. Close the control panel cover.

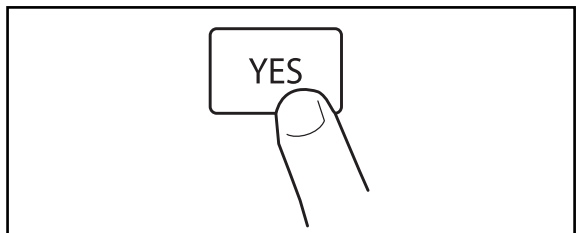

3012-302

Turn off Auto Mower

1. Press the STOP button.
2. Set the main switch to the OFF position.

Always switch off the Auto Mower using the main switch if you intend to perform maintenance or move the mower outside of the working area.

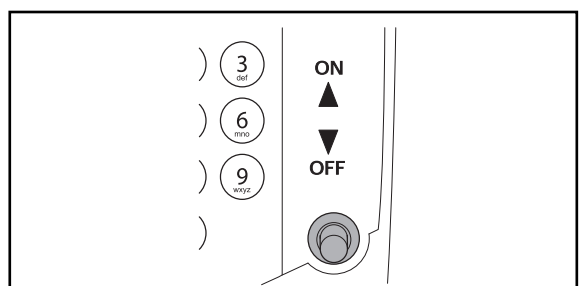

3012-250

USE

Adjusting the cutting height

The cutting height is calculated as the distance from the ground in centimetres. The cutting height can be varied using 10 different positions from MIN (2 cm) to MAX (6 cm).

If the grass is long it is appropriate to let Auto Mower start mowing at the MAX cutting height. Once the grass is shorter, you can gradually lower the cutting height.

To adjust the cutting height:

1. Press the STOP button to stop the mower.
2. Open the cutting height adjustment cover:
Slide the catch button forward and then open the cover.

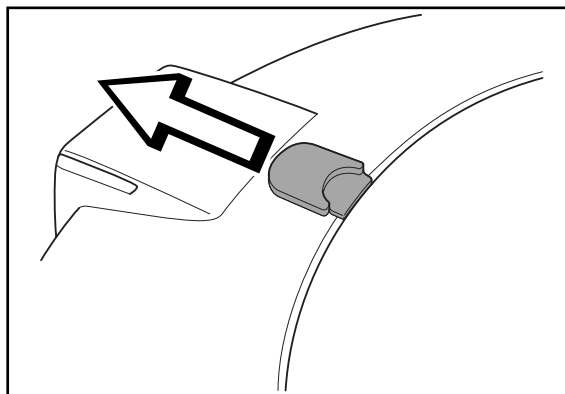

3012-251

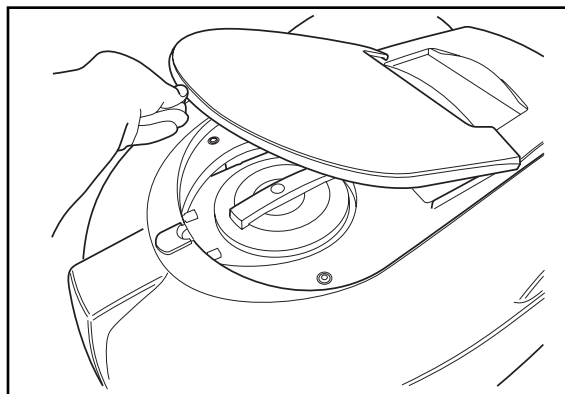

3012-252

3. Turn the knob to the required position. The selected position is the marking on the knob that aligns with the arrow on the body.
 - Turn clockwise to raise the cutting height.
 - Turn anticlockwise to lower the cutting height.

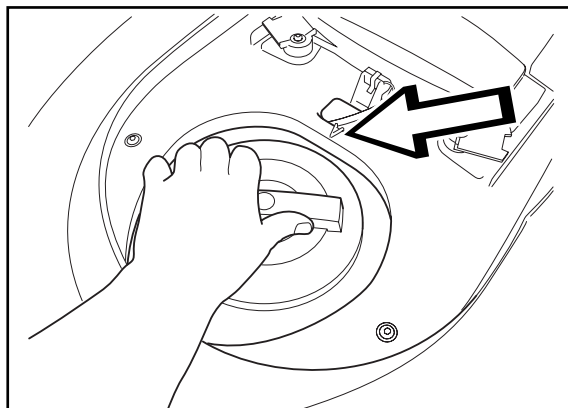

3012-253

4. Close the cover. Ensure that the catch button locks.

Maintenance

Check and clean the Auto Mower regularly and replace worn parts if necessary to improved operating reliability and to give a longer service life.

During the initial period of Auto Mower use the blade disc, skid plate and blades should be checked once a week. If the amount of wear during this period has been low, the inspection interval can be increased.

It is important that the blade disc rotates easily. The skid plate should rotate easily in relation to the blade disc. The edges of the blades should not be damaged. The service life of the blades depends on:

- Operating time and size of the working area.
- Type of grass.
- Type of soil.
- The presence of objects such as cones, windfalls, toys, tools, stones, roots and the like.

The service life can vary greatly, but is normally 2-4 weeks of operation over areas larger than 1000 m² longer in smaller areas.

Battery

The battery is maintenance free, but has a limited life span of 1-3 years. The battery may only be replaced by a dealer. Battery life is dependent on the length of the season and how many hours per day the Auto Mower is used. A long season or many hours of use per day, means that the battery must be replaced more regularly.

Winter Storage

Auto Mower:

Clean the Auto Mower carefully and set the main switch in the "OFF" position. Store the mower indoors, in the original packaging, standing on all four wheels.

Charging station:

If possible store the charging station, transformer and low voltage cable indoors. Remember to protect the ends of the boundary wire from moisture by placing them, for example, in a tin with anhydrous grease.

If indoor storage is not possible the boundary wire should remain connected. The charging station should remain connected to the mains supply.

After winter storage:

Check whether the Auto Mower, contact strips or charging strips need to be cleaned before using. If the charging or contact stripes appear to be burnt, clean them using fine grade emery cloth. Check that the mower's time and date are correct.

MAINTENANCE

Cleaning

Never use a high-pressure washer or even running water to clean the Auto Mower.

We recommend a spray bottle with water.

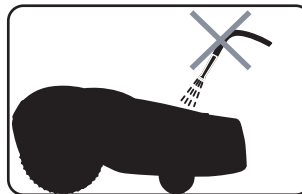

3012-271

Underframe and blade disc

1. Set the main switch to the OFF position.
2. Wear protective gloves.

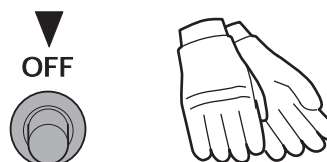

3012-288
3012-272

3. Lift the Auto Mower onto its side.
4. Clean the blade disc and underframe using, e.g. a dish-brush.

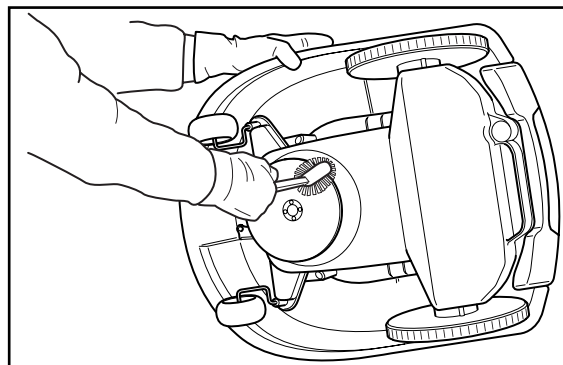

3012-255

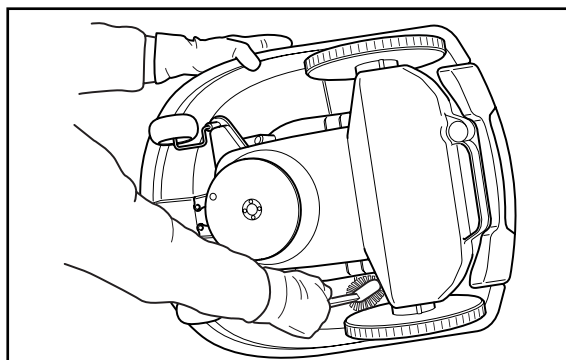

3012-256

Body

Use a damp, soft sponge or cloth to clean the body. If the body is very dirty it may be necessary to use a soap solution or washing-up liquid.

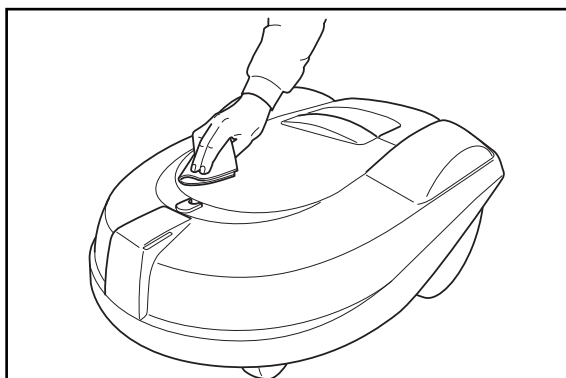

3012-254

MAINTENANCE

Replacing the blade units



WARNING

Always use original blade units when replacing.

Only replacing the blade and reusing the screw and washer, can result in the screw wearing during mowing and shearing off. The blade can then be thrown causing serious injury.

There are three blade units on the blade disc. Each unit consists of a screw, a blade and a lock washer.

Always replace all three blade units at the same time, to obtain a balanced mowing system.

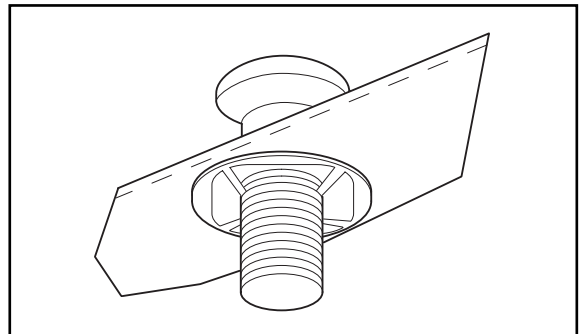

3012-259

1. Set the main switch to the OFF position.
2. Wear protective gloves.



3012-288
3012-272

3. Turn the Auto Mower upside down.
4. Rotate the skid plate so that its holes align over the blade unit screws.
5. Unscrew the blade unit.
Use a straight slot or cross-tip screwdriver.

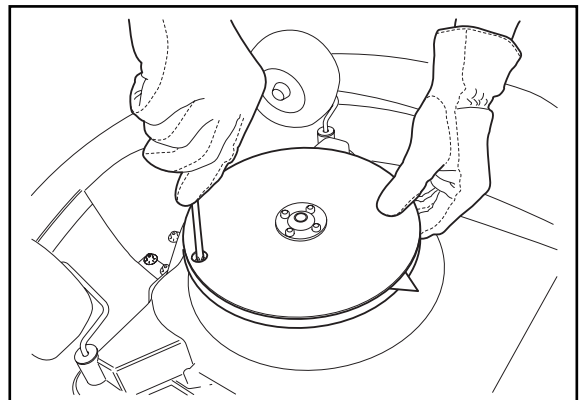

3012-260

6. Pry apart the skid plate and blade disc a little and remove the blade unit.
7. Fit the new blade unit.

TROUBLE SHOOTING

Trouble shooting

Fault messages

A number of fault messages are listed below that can be shown on the display. If another message than those listed is shown, contact your dealer.

| Fault message | Cause | Action |
|----------------------------------|---|---|
| Left wheel motor blocked | Grass or other object may have become wrapped around the drive wheel. | Check the drive wheel and remove the grass or other object. |
| Right wheel motor blocked | Grass or other object may have become wrapped around the drive wheel. | Check the drive wheel and remove the grass or other object. |
| Blade disc blocked | Grass or another object may have become wrapped around the blade disc. | Check the blade disc and remove the grass or other object. |
| No loop signal | Wrong PIN code has been stated. | State the correct PIN code. |
| | The transformer is not connected to the mains supply or its miniature circuit-breaker has tripped. | Check the wall socket connection and whether the miniature circuit-breaker has tripped. Reset the miniature circuit-breaker by removing the transformer's power cord from the wall socket, wait 10 seconds and then reconnect the power cord in the wall socket again. |
| | Boundary wire broken. | Check the signal given by the LED on the charging station. If it flashes the loop is damaged. Repair the broken cable using Husqvarna's waterproof connector, part number 535 13 37-01. |
| | If this occurs in isolated areas it may be due to interference from metallic objects (perimeter fence, reinforcement bar) or buried cables in the vicinity. | Try to move the boundary wire. |
| | If it occurs in the vicinity of an "island" it may be due to the boundary wire be routed in the wrong direction around "island" and thereby switching off the signal. | Check that the boundary wire has been routed correctly. |
| Trapped | Auto Mower has become caught in something. | Free the Auto Mower and rectify the reason for it becoming trapped. |

TROUBLE SHOOTING

| Fault message | Cause | Action |
|---------------------------------------|---|---|
| Outside | If this occurs in isolated areas it may be due to interference from metallic objects (perimeter fence, reinforcement bar) or buried cables in the vicinity. | Try to move the boundary wire. |
| | The working area slopes too much. | Check that the boundary wire has been routed correctly. |
| | The boundary wire has been routed the wrong way around an "island". | Check that the boundary wire has been routed in accordance with the installation instructions. |
| | The boundary wire is too close to the edge of the working area. | Check that the boundary wire has been routed correctly. |
| Low battery voltage | Auto Mower cannot find the charging station. | Change the position of the charging station. |
| | The battery is defective. | Contact your dealer to replace the battery |
| Wrong PIN code | Wrong PIN code has been entered. Three attempts are permitted, the keypad is then blocked for five minutes. | State the correct PIN code. |
| No drive | Auto Mower has become caught in something. | Free the mower and rectify the reason for the lack of drive. If it is due to wet grass, wait until the lawn has dried before using the mower. |
| No contact in charging station | The Auto Mower makes poor contact with the contact strips in the charging station. | Check that the Auto Mower has docked correctly in the charging station. |
| Charging station blocked | The contact between the charging strips and contact strips may be poor and the Auto Mower has made a number of charging attempts. | Place the Auto Mower in the charging station and check that the charging strips and contact strips make good contact. |
| | An object is obstructing the Auto Mower | Remove the object. |
| Stuck in charging station | An object is preventing the Auto Mower from reversing out of the charging station. | Remove the object. |
| Upside down | The Auto Mower leans too much or has turned over. | Turn the mower the right way up. |
| Empty battery | The Auto Mower is set in MAN operating mode. | This behaviour is normal; no action required. |

TROUBLE SHOOTING

Trouble Shooting Guide

If your Auto Mower does not work correctly, follow the trouble shooting guide below. If the fault persists; contact your dealer.

| Symptom | Cause | Action |
|--|--|--|
| Uneven cutting result | Auto Mower works too few hours per day. | Increase the mowing time, see "2. Timer" on page 30. |
| | Too large working area. | Try to limit the working area or extend the working time, see "2. Timer" on page 30. |
| | Dull blades. | Replace all the blade units so that the rotating parts are balanced. |
| | Long grass in relation to the set cutting height. | Increase the cutting height. At the beginning of the season you may need to mow the lawn the first time with a conventional lawn mower before the Auto Mower is put to work. |
| | Grass accumulation by the blade disc or around the motor shaft. | Check that the skid plate and blade disc rotate easily. If not, the skid plate and perhaps the blade disc must be removed and the grass and foreign objects removed. |
| Auto Mower runs at the wrong time | The Auto Mower clock needs to be set. | Set the clock, see "4. Settings" on page 35. |
| | The start and stop times for mowing are incorrect. | Adjust the start and stop time setting for mowing, see "2. Timer" on page 30. |
| Auto Mower vibrates | Unbalanced blade disc or damaged blades. | Inspect the blade units and replace them if necessary. |
| Auto Mower runs, but the blade disc does not rotate | The Auto Mower is looking for the charging station. | No action The blade disc does not rotate when the mower is searching for the charging station. |
| The mower mows for shorter periods than usual between charges | Grass or a foreign object is blocking the blade disc or skid plate. | Dismantle and clean the skid plate and blade disc. |
| Both the mowing and charge times are shorter than usual | This behaviour is normal in high temperatures (gradually increasing above 25°C). | No action |

TECHNICAL DATA

Technical Data

| Data | Auto Mower |
|--------------------------|---|
| Dimensions | |
| Length | 71 cm |
| Width | 56 cm |
| Height | 30 cm |
| Weight | 8.6 kg |
| Electrical system | |
| Battery | NiMH special battery 18V / 2,2 Ah (40 Wh) |
| Transformer | 230 V / 24 V |
| Noise emissions | |
| Measured noise level | 63 dB(A) |
| Guaranteed noise level | 70 dB(A) |
| Mowing | |
| Mowing system | Three, pivoted cutting knife blades |
| Cutting Height | 2 -6 cm |
| Cutting width | 22 cm |
| Working capacity | 1800 m ² |

EU DECLARATION OF CONFORMITY

EU declaration of conformity

EU Declaration of Conformity (only applies to Europe)

We, **Husqvarna AB**, SE-561 82 Huskvarna, Sweden, tel: +46-36-146500, declares under sole responsibility that the automatic lawn mower **Husqvarna Auto Mower** from 2003's serial numbers and onward (the year is clearly stated in plain text on the rating plate with subsequent serial number), conforms with the requirements of the COUNCIL'S DIRECTIVE:

-of June 22, 1998 "relating to machinery" **98/37/EC, annex IIA.**

-of May 3, 1989 "relating to electromagnetic compatibility" **89/336/EEC**, and applicable supplements.

-of May 8, 2000 "relating to the emission of noise to surroundings" **2000/14/EC.**

Information regarding noise emissions and the cutting width, see Technical Data.

The following standards have been applied: **EN292-2.**

The registered body **0404, SMP Svensk Maskinprovning AB**, Fyrstorgsgatan 3, SE-754 50 Uppsala, Sweden, has issued the report with number **01/901/027** regarding the assessment of conformity according to annex VI to the COUNCIL'S DIRECTIVE of May 8, 2000 "relating to the emission of noise to surroundings" **2000/14/EC.**

Huskvarna March 6, 2003



Roger Andersson, Development manager

Serial number: _____

Personal code: _____

Dealer _____

Dealer's telephone number: _____



114 01 48-26



2003W23